

E210 DIAMETER FRAMES

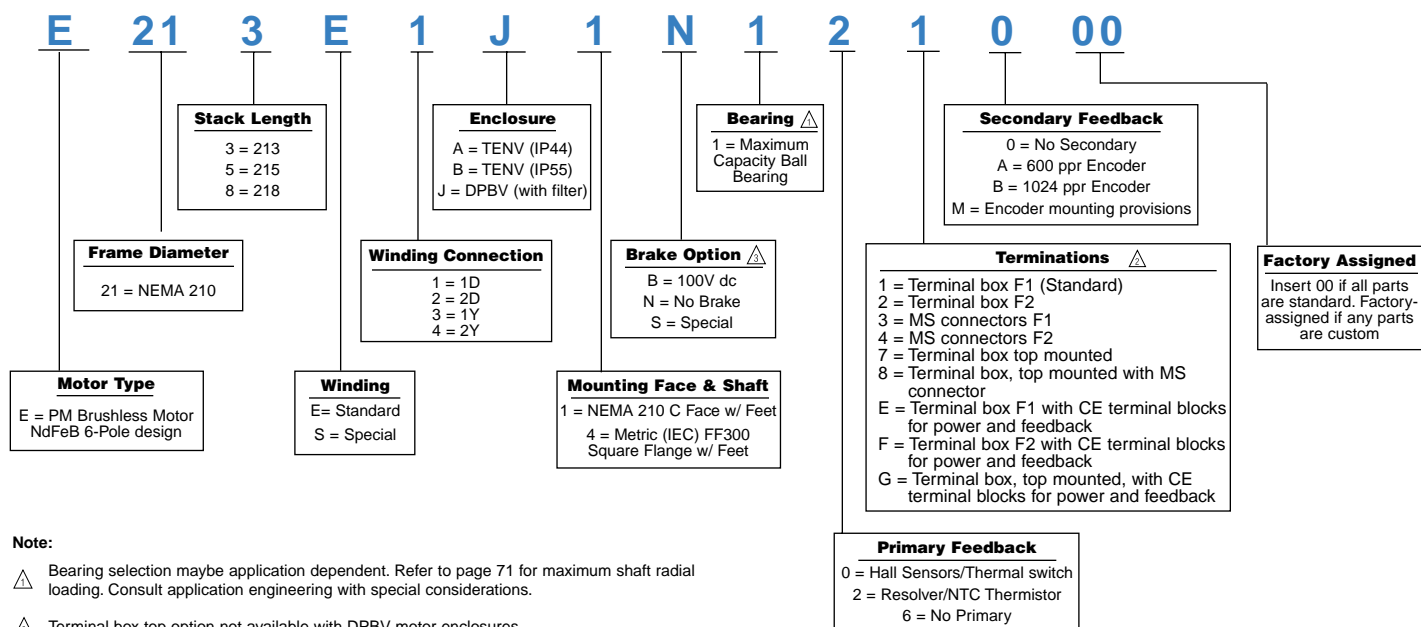

MODEL NUMBER CODE...E210 FRAME

To construct a motor listing, select the combination of features required, and put all the coded information in the proper sequence. Please account for all the entries. The model number shown is an example of a properly specified motor.



E210 DIAMETER FRAMES



RATINGS AND CHARACTERISTICS

Motor parameters and winding data

ENGLISH

METRIC

Parameters, DPBV & TENV	Symbol	Units	E213	E215	E218	Symbol	Units	E213	E215	E218
Continuous stall torque $\triangle \triangle$	T_{CS}	lb-ft	128 (64)	160 (81)	190 (100)	T_{CS}	Nm	192 (87)	217 (110)	258 (136)
Peak Torque (theoretical) $\triangle \triangle$	T_{PK}	lb-ft	420	554	720	T_{PK}	Nm	569	751	976
Inertia (motor only)	J_M	lb-ft-sec ²	.0256	.0298	.0356	J_M	kgm ² x 10 ⁻³	34,7	40,4	48,3
Static friction (max.)	T_f	lb-ft	.44	.58	.71	T_f	Nm	,60	,79	,96
Viscous Damping coefficient \triangle	K_{DV}	lb-ft/Krpm	1.08	1.45	1.93	K_{DV}	Nm/Krpm	1,46	1,97	2,62
Thermal resistance \triangle	R_{TH}	°C/Watt	.035 (.148)	.031 (.130)	.029 (.110)	R_{TH}	°C/Watt	.035 (.148)	.031 (.130)	.029 (.110)
Thermal time constant \triangle	τ_{TH}	min.	30 (130)	32 (130)	36 (140)	τ_{TH}	min.	30 (130)	32 (130)	36 (140)
Weight \triangle	W	lbs.	175 (164)	211 (200)	261 (250)	M (mass)	kg	79,6 (75)	95,9 (90,9)	118,6 (113,6)

Winding data	Symbol	Units	E213				E215				E218			
			E1	E2	E3	E4	E1	E2	E3	E4	E1	E2	E3	E4
Torque Constant line-line \triangle	K_T rms	lb-ft/A Nm/A	3.22	1.61	5.58	2.79	3.02	1.51	5.23	2.62	2.96	1.48	5.13	2.56
			4.37	2.18	7.56	3.78	4.09	2.05	7.09	3.55	4.01	2.01	6.95	3.48
Voltage Constant line-line \triangle	K_E rms	V/Krpm V/rad/sec	264	132	457	229	248	124	429	215	243	122	421	210
			2.52	1.26	4.37	2.18	2.37	1.18	4.10	2.05	2.32	1.16	4.02	2.01
Continuous stall current $\triangle \triangle \triangle$	I_{CS}	A	44(22)	88(44)	28(13)	50(25)	58(29)	118(60)	34(17)	67(34)	71(37)	142(75)	42(22)	82(43)
Current at peak torque $\triangle \triangle \triangle$	I_{PK}	A	131	262	76	151	184	367	106	212	244	488	141	282
Hot Resistance line-line \triangle	R_H	Ohms	0.84	.021	2.51	0.63	0.54	0.14	1.61	0.40	0.37	0.093	1.12	0.28
Cold Resistance line-line \triangle	R_C	Ohms	0.58	0.14	1.73	0.43	0.37	0.093	1.11	0.28	0.26	0.064	0.77	0.19
Inductance line-line	L	mH	11.4	2.85	34.3	8.56	7.64	1.91	22.9	5.73	5.67	1.42	17	4.25
Electrical time constant \triangle	τ_e	msec	19.8	19.8	19.8	19.8	20.5	20.5	20.5	20.5	22.2	22.2	22.2	22.2
Mechanical time constant \triangle	τ_m	msec	1.57	1.57	1.57	1.57	1.32	1.32	1.32	1.32	1.14	1.14	1.14	1.14
Rated base speed \triangle	ω_r	rpm	1750	3600	1000	2000	1750	3600	1000	2000	1750	3600	1000	2000
Rated current @ rated speed, RMS Amperes	I_R	A	43.3	77.2	26.0	49.3	54.7	94.0	33.0	62.0	63.6	100.0	38.8	72.0
			(17.4)	(N/A)	(11.9)	(18.5)	(20.9)	(N/A)	(15.2)	(21.4)	(23.0)	(N/A)	(18.1)	(21.7)
Power @ rated speed \triangle	P_R	HP, DPBV (TENV)	40.2	73.4	21.5	45.3	49.2	86.2	29.3	55.3	57.0	92.6	34.5	63.6
			(15.7)	(N/A)	(10.7)	(16.5)	(18.2)	(N/A)	(13.2)	(18.3)	(19.9)	(N/A)	(15.8)	(18.5)
Power @ rated speed \triangle	P_R	kW, DPBV (TENV)	30.0	54.8	16.0	33.8	36.7	64.3	21.9	41.3	42.5	69.1	25.7	47.4
			(11.7)	(N/A)	(8.0)	(12.3)	(13.6)	(N/A)	(9.8)	(13.7)	(14.8)	(N/A)	(11.8)	(13.8)

Note: All values at 40°C unless otherwise noted.

- \triangle 25°C ambient temperature
- \triangle () denotes TENV when dual ratings are shown. Single ratings apply to both
- \triangle Based on RMS (sine wave) amps
- \triangle 140°C winding temperature
- \triangle 640V dc
- \triangle Theoretical (cold) ratings at peak current, I_{PK} . For ratings at rated temperature, see Torque-Speed curves, pages 20-22
- \triangle Demagnetization current for 150°C magnet temperature

DIMENSIONS . . . 210 Diameter Frames; DPBV (Dripproof, Blower Ventilated)

FRONT VIEW

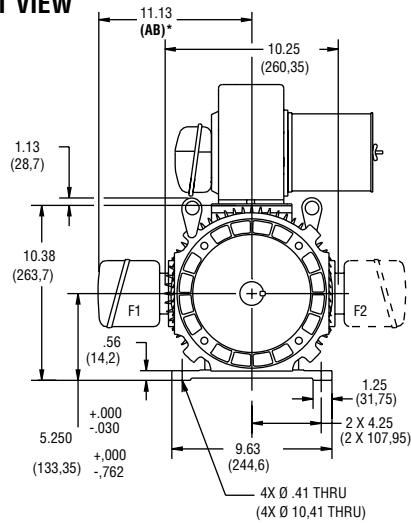

SIDE VIEW

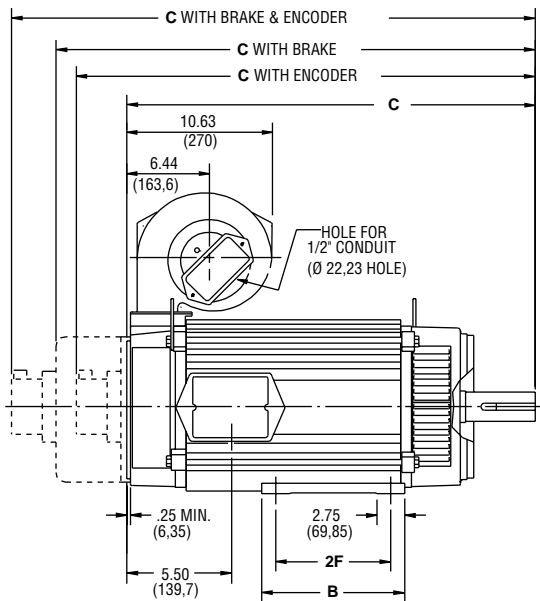

CALLOUT FOR "C" DIMENSION				
MODEL	MOTOR ONLY	WITH ENCODER	WITH BRAKE	WITH BRAKE & ENCODER
E213	22.25 (565,15)	25.04 (636)	26.14 (664)	28.10 (713,7)
E215	26.88 (682,75)	29.67 (753,6)	30.77 (781,6)	32.73 (831,3)
E218	29.25 (742,95)	32.04 (813,8)	33.14 (841,8)	35.10 (891,5)

MODEL	2F DIMENSION	B DIMENSION
E213	5.50 (139,7)	8.38 (212,85)
E215	7.00 (177,8)	8.38 (212,85)
E218	10.00 (254)	11.38 (289,1)

Dimensions in () are mm, all others in inches

REAR VIEW

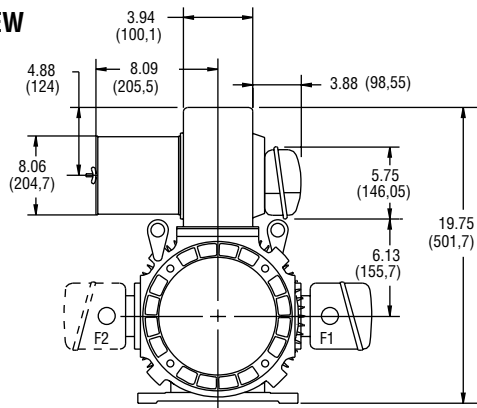

NOTE:

- Reference pages 56, 57 for conduit box dimensions.
- Conduit box can be rotated in 90° steps on its own axis and can be mounted on opposite side or top when specified.
- Blower can be rotated 180° about its axis. Size #3 blower is used on E210 frames. See Page 67.

* See terminations, page 56.

DIMENSIONS . . . 210 Diameter Frames; TENV (Totally Enclosed, Non-Ventilated)

FRONT VIEW

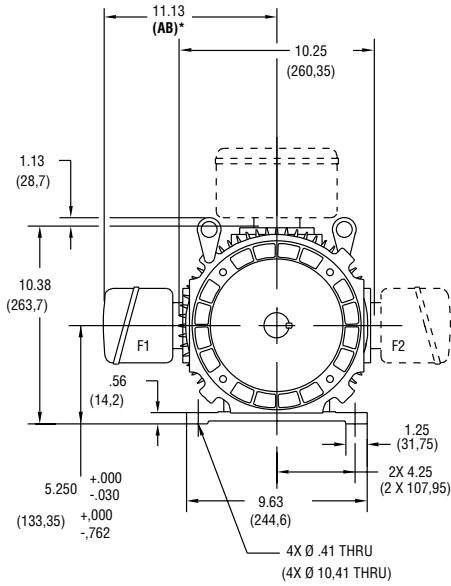

SIDE VIEW

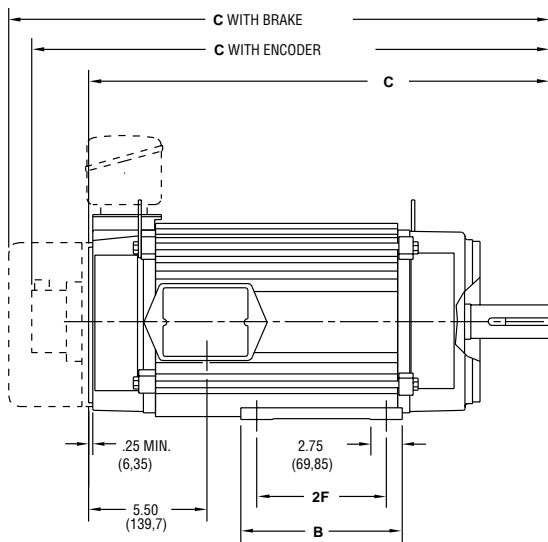

CALLOUT FOR "C" DIMENSION				
MODEL	MOTOR ONLY	WITH ENCODER	WITH BRAKE	WITH BRAKE & ENCODER
E213	$\frac{22.25}{(565,15)}$	$\frac{25.04}{(636)}$	$\frac{26.14}{(664)}$	$\frac{28.10}{(713,7)}$
E215	$\frac{26.88}{(682,75)}$	$\frac{29.67}{(753,6)}$	$\frac{30.77}{(781,6)}$	$\frac{32.73}{(831,3)}$
E218	$\frac{29.25}{(742,95)}$	$\frac{32.04}{(813,8)}$	$\frac{33.14}{(841,8)}$	$\frac{35.10}{(891,5)}$

MODEL	2F DIMENSION	B DIMENSION
E213	$\frac{5.50}{(139,7)}$	$\frac{8.38}{(212,85)}$
E215	$\frac{7.00}{(177,8)}$	$\frac{8.38}{(212,85)}$
E218	$\frac{10.00}{(254)}$	$\frac{11.38}{(289,1)}$

Dimensions in () are mm, all others in inches

REAR VIEW

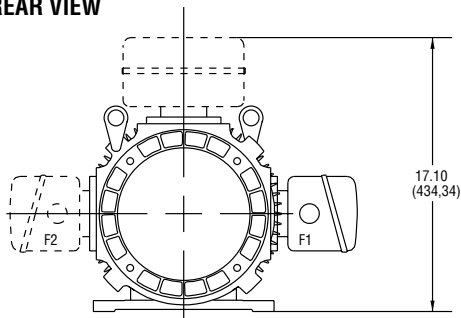

NOTE:

1. Reference pages 56, 57 for conduit box dimensions.
2. Conduit box can be rotated in 90° steps on its own axis and can be mounted on opposite side or top when specified.

* See terminations, page 56.

DIMENSIONS ... 210 Diameter Frame Mounting; NEMA and Metric

NEMA C FACE

Dimensions in inches

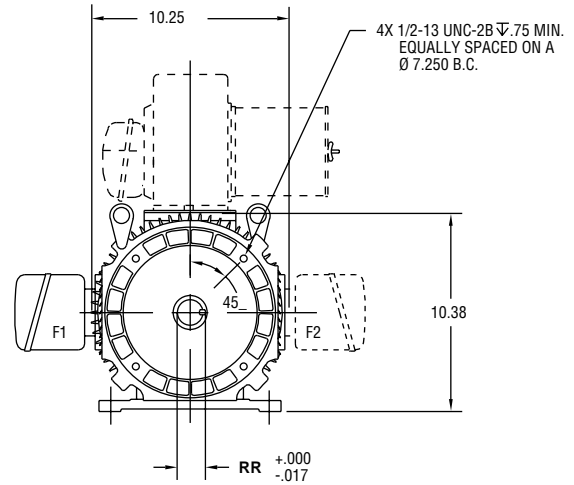
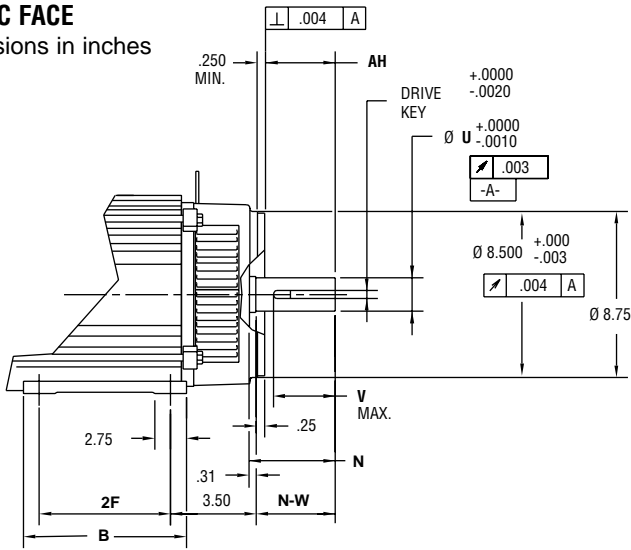

REFER TO DPBV, PAGE 17, FOR FRONT VIEW FEET DIMENSIONS

MODEL	2F	B	AH	N	N-W	U	V	RR	Drive Key
E213	5.50	8.38	3.75	4.31	4.00	1.625	3.5	1.791	.375
E215	7.00	8.38	5.00	5.56	5.25	2.125	4.75	2.345	.500
E218	10.00	11.38	5.00	5.56	5.25	2.125	4.75	2.345	.500

ALTERNATE MOUNTING

Metric (IEC) FF300
Dimensions in mm

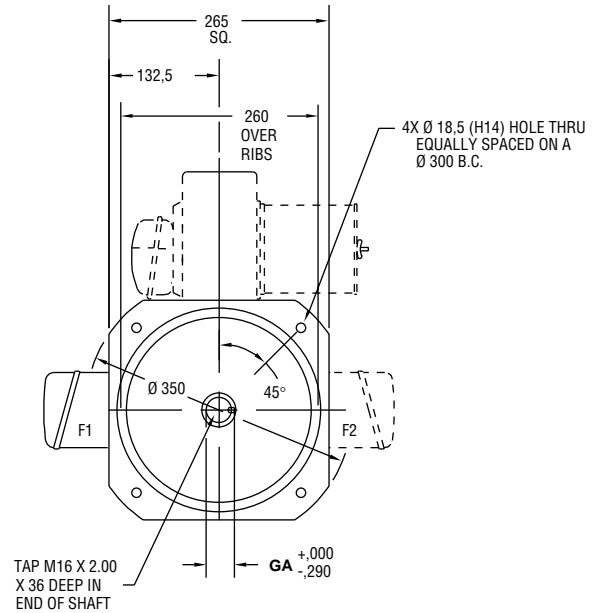
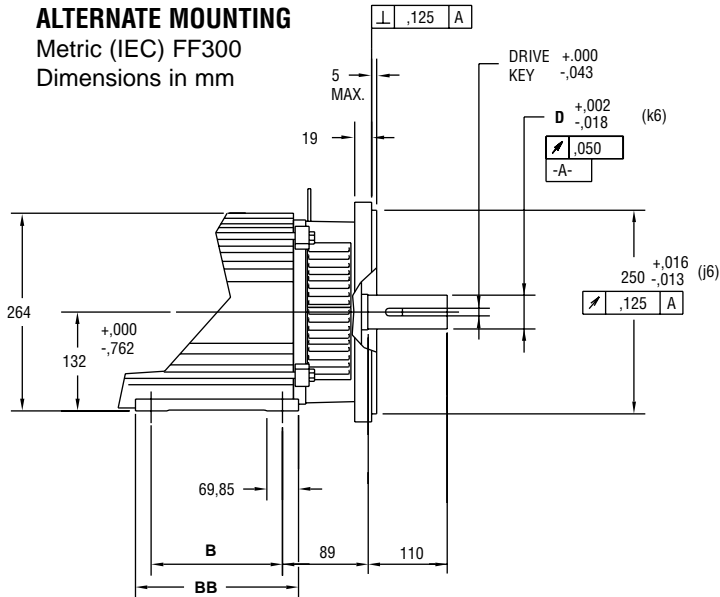

EXCEPT FOR FOOT HEIGHT REFER TO DPBV, PAGE 17, FOR FRONT VIEW FEET DIMENSIONS

MODEL	D	B	BB	GA	Drive Key
E213	42	139,7	213	45	12
E215	48	177,8	213	51,5	14
E218	48	254	289	51,5	14

PERFORMANCE CURVES

210 FRAME E213

Test Conditions

- Motor operated in ambient temperature of 40° C maximum that results in a maximum motor stator winding temperature of 140° C
- 640V dc bus applied
- Sinusoidal drive output

- Intermittent duty
- Continuous duty

DPBV DRIPPROOF BLOWER VENTILATED

TENV TOTALLY ENCLOSED NON-VENTILATED

E213E3 MOTOR

Reference Points	
T_{PK}	368
T_{CS}	128
T_{CR}	113
W_R	1,000
I_{CS}	28.0
I_{CR}	26.0

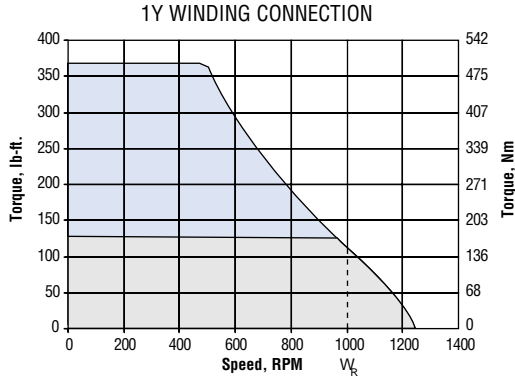

E213E3 MOTOR

Reference Points	
T_{PK}	368
T_{CS}	64
T_{CR}	56
W_R	1,000
I_{CS}	13.0
I_{CR}	11.9

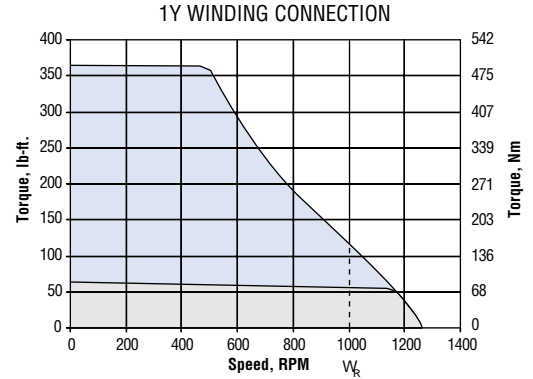

E213E1 MOTOR

Reference Points	
T_{PK}	368
T_{CS}	128
T_{CR}	120
W_R	1,750
I_{CS}	44.0
I_{CR}	43.4

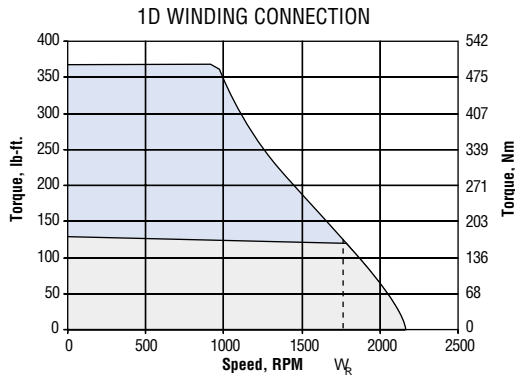

E213E1 MOTOR

Reference Points	
T_{PK}	368
T_{CS}	64
T_{CR}	47
W_R	1,750
I_{CS}	22.0
I_{CR}	17.4

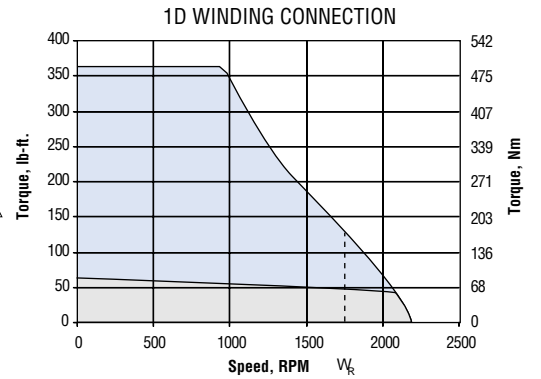

E213E4 MOTOR

Reference Points	
T_{PK}	368
T_{CS}	128
T_{CR}	118
W_R	2,000
I_{CS}	50.0
I_{CR}	49.3

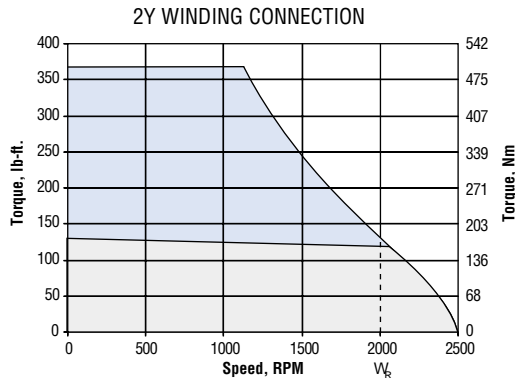

E213E4 MOTOR

Reference Points	
T_{PK}	368
T_{CS}	64
T_{CR}	43
W_R	2,000
I_{CS}	25.0
I_{CR}	18.5

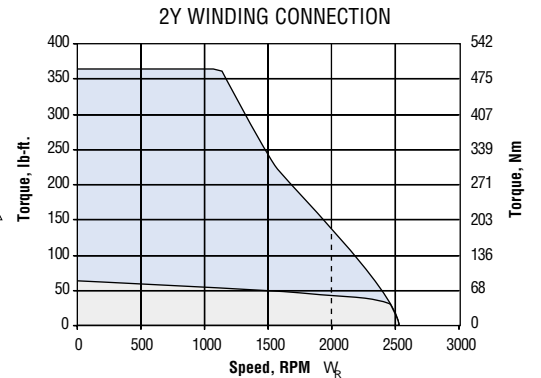

E213E2 MOTOR

Reference Points	
T_{PK}	368
T_{CS}	128
T_{CR}	107
W_R	3,600
I_{CS}	88.0
I_{CR}	77.2

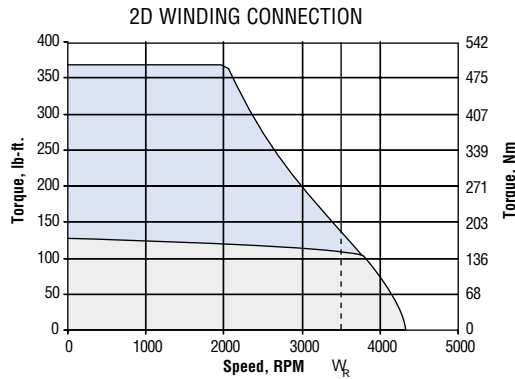

E213E2 MOTOR

Reference Points	
T_{PK}	368
T_{CS}	64
T_{CR}	-
W_R	-
I_{CS}	44
I_{CR}	-

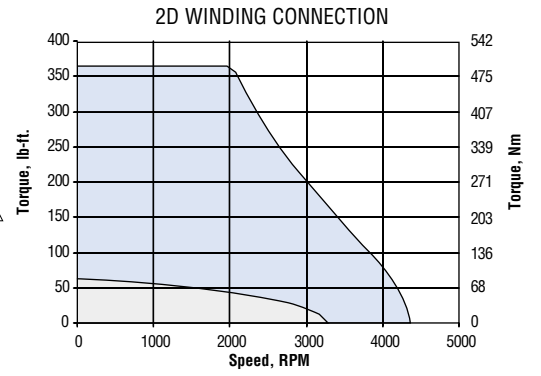

- See model number code, page 15.
- This is also the demagnetization limit. User should apply appropriate safety margins in its use.

- Notes:
1. See Motor Performance Curves, page 76.
 2. See Thermal Protection, page 69.
 3. See Power Curves, page 23.
 4. See Efficiency Curves, page 24.

PERFORMANCE CURVES

210 FRAME E215

Test Conditions

- Motor operated in ambient temperature of 40° C maximum that results in a maximum motor stator winding temperature of 140° C
- 640V dc bus applied
- Sinusoidal drive output

- Intermittent duty
- Continuous duty

DPBV DRIPPROOF BLOWER VENTILATED

TENV TOTALLY ENCLOSED NON-VENTILATED

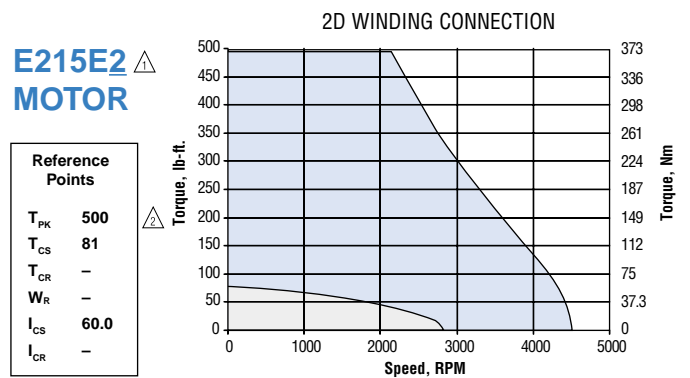
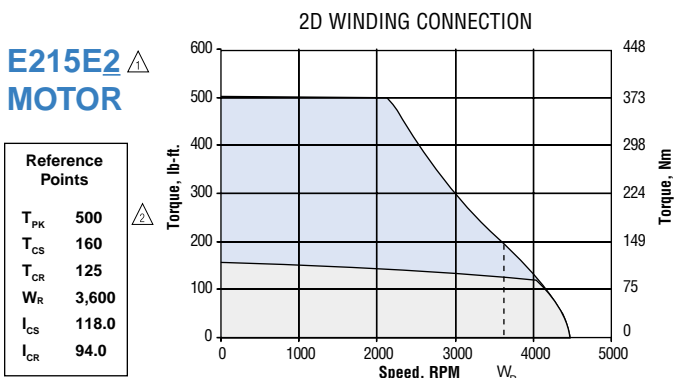
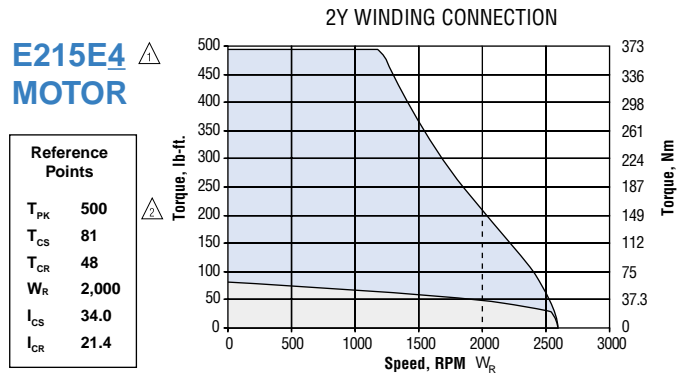
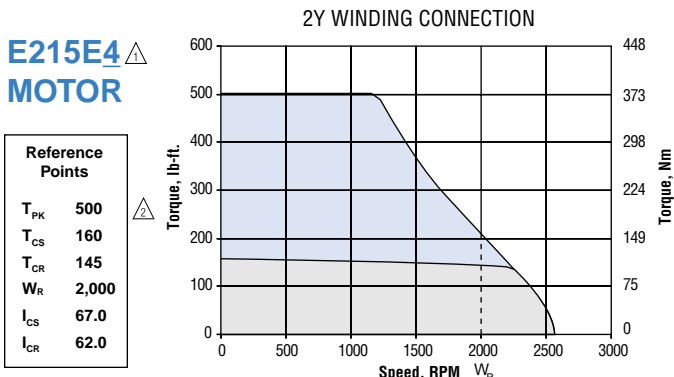
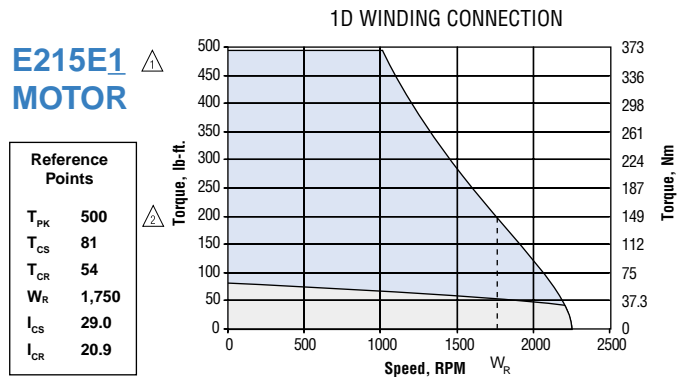
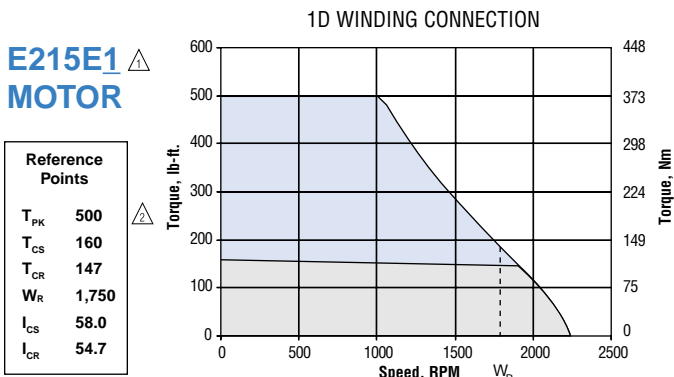
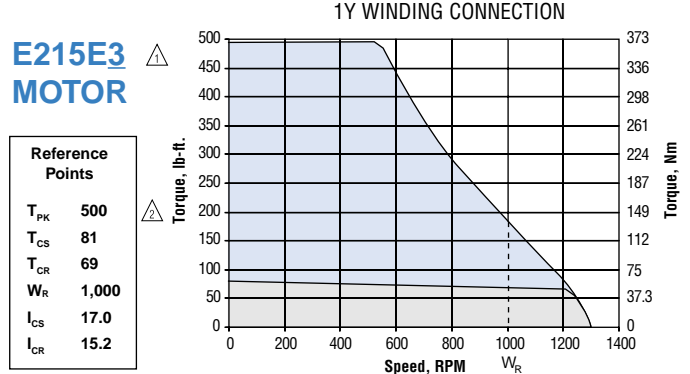
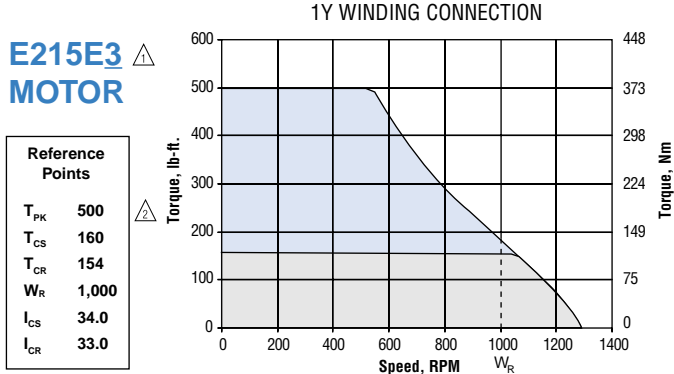

- See model number code, page 15.
- This is also the demagnetization limit. User should apply appropriate safety margins in its use.

- Notes:
1. See Motor Performance Curves, page 76.
 2. See Thermal Protection, page 69.
 3. See Power Curves, page 23.
 4. See Efficiency Curves, page 24.

PERFORMANCE CURVES

210 FRAME E218

Test Conditions

- Motor operated in ambient temperature of 40° C maximum that results in a maximum motor stator winding temperature of 140° C
- 640V dc bus applied
- Sinusoidal drive output

- Intermittent duty
- Continuous duty

DPBV
DRIPPROOF
BLOWER VENTILATED

TENV
TOTALLY ENCLOSED
NON-VENTILATED

E218E3 MOTOR

Reference Points	
T_{PK}	660
T_{CS}	190
T_{CR}	181
W_R	1,000
I_{CS}	42.0
I_{CR}	38.8

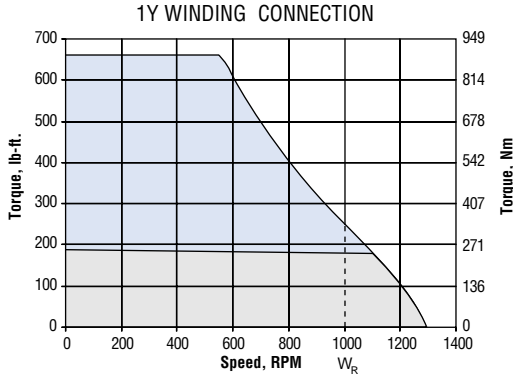

E218E3 MOTOR

Reference Points	
T_{PK}	660
T_{CS}	100
T_{CR}	82.8
W_R	1,000
I_{CS}	22.0
I_{CR}	18.2

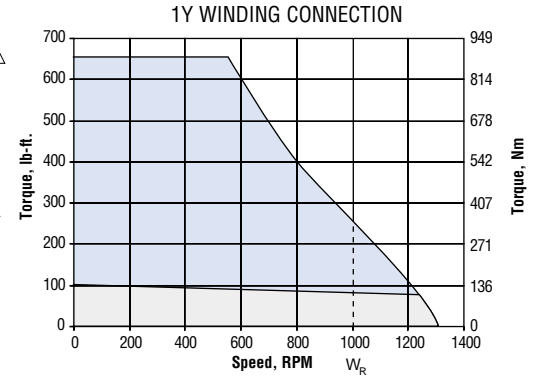

E218E1 MOTOR

Reference Points	
T_{PK}	660
T_{CS}	190
T_{CR}	171
W_R	1,750
I_{CS}	71.0
I_{CR}	63.6

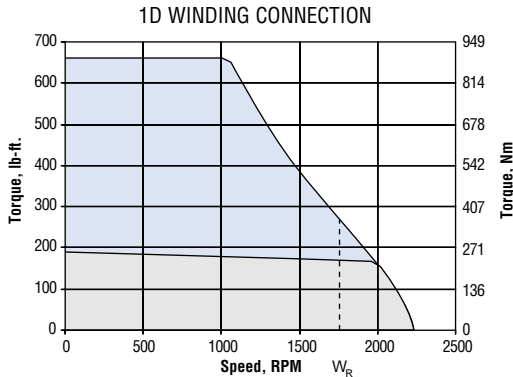

E218E1 MOTOR

Reference Points	
T_{PK}	660
T_{CS}	100
T_{CR}	59.6
W_R	1,750
I_{CS}	37.0
I_{CR}	23.0

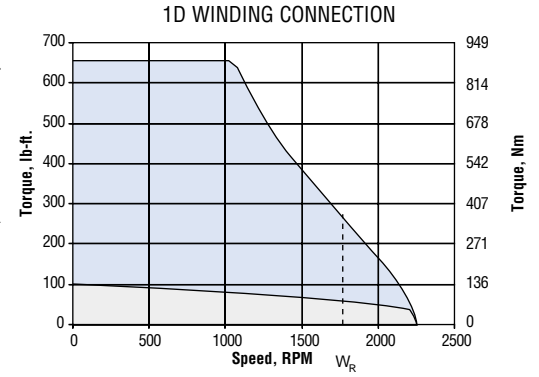

E218E4 MOTOR

Reference Points	
T_{PK}	660
T_{CS}	190
T_{CR}	167
W_R	2,000
I_{CS}	82.0
I_{CR}	72.0

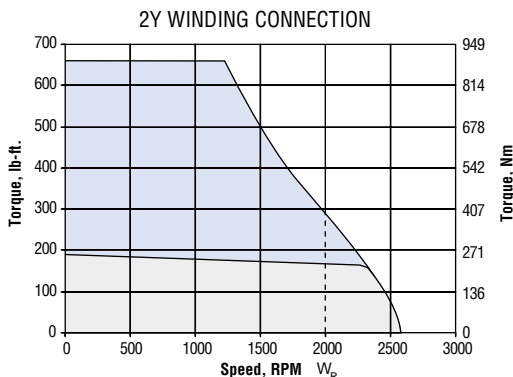

E218E4 MOTOR

Reference Points	
T_{PK}	660
T_{CS}	100
T_{CR}	48.4
W_R	2,000
I_{CS}	43.0
I_{CR}	21.7

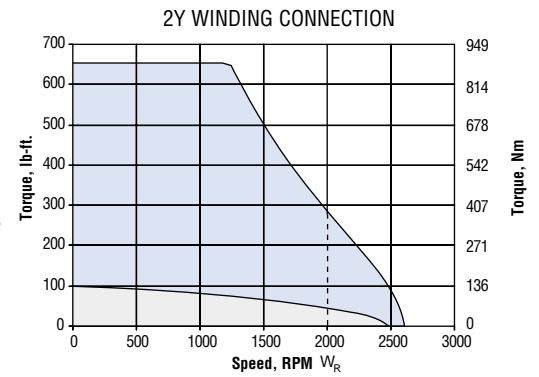

E218E2 MOTOR

Reference Points	
T_{PK}	660
T_{CS}	190
T_{CR}	135
W_R	3,600
I_{CS}	142.0
I_{CR}	100.0

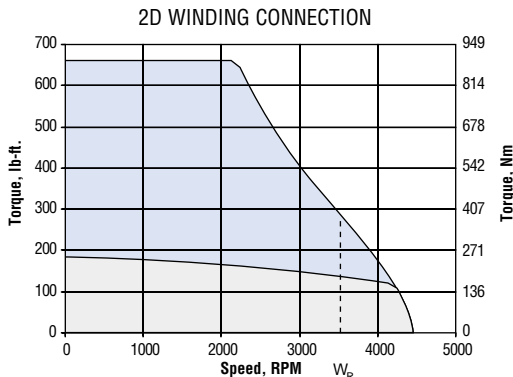

E218E2 MOTOR

Reference Points	
T_{PK}	660
T_{CS}	100
T_{CR}	-
W_R	-
I_{CS}	75.0
I_{CR}	-

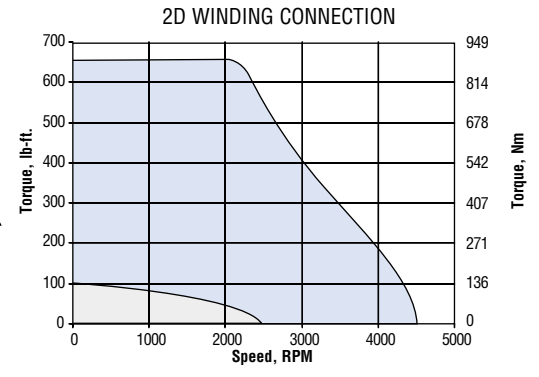

- △ See model number code, page 15.
- △ This is also the demagnetization limit. User should apply appropriate safety margins in its use.

- Notes:
1. See Motor Performance Curves, page 76.
 2. See Thermal Protection, page 69.
 3. See Power Curves, page 23.
 4. See Efficiency Curves, page 24.

CONTINUOUS POWER CURVES

E210 DIAMETER FRAMES

Standard E210 frame motors are limited (mechanical design) to 4500 RPM. Special designs are available that allow operation to speeds indicated in the individual curves.

One power curve is shown for each stack length in both the DPBV and TENV enclosures. Four different winding connections are offered for each stack length, but the power curve is the same for all connections. Therefore, only one power curve is necessary for each stack length and enclosure.

DPBV DRIPPROOF BLOWER VENTILATED

TENV TOTALLY ENCLOSED NON-VENTILATED

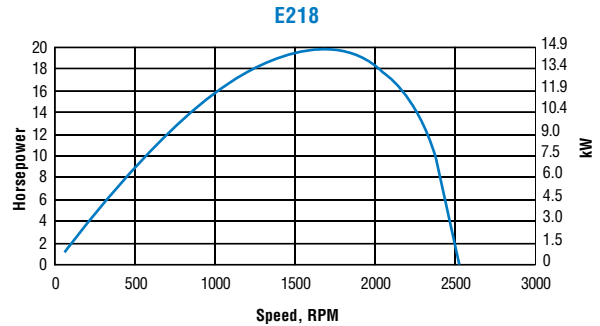
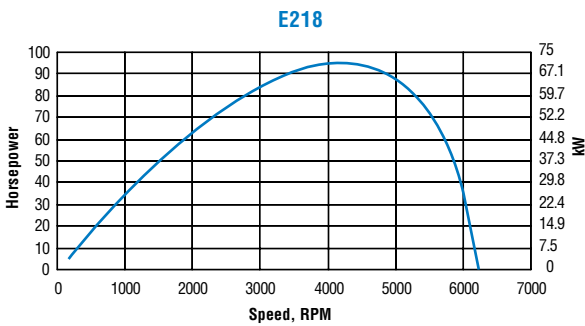
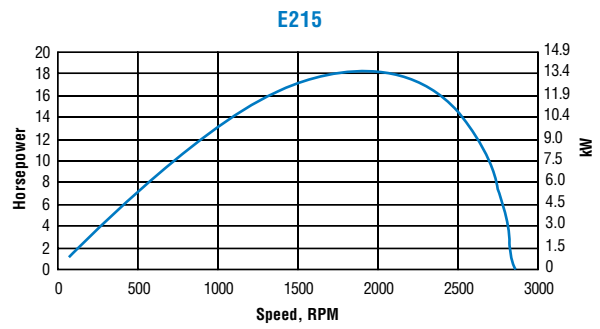
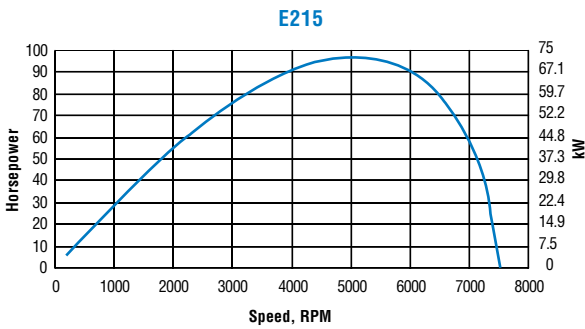
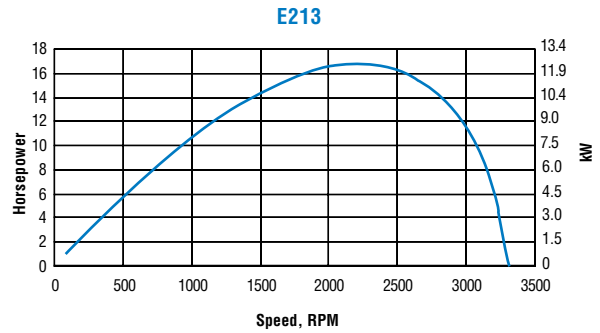
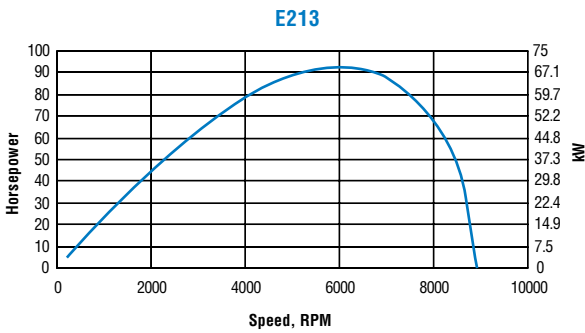

Note: see Motor Performance Curves, page 76.

EFFICIENCY CURVES

E210 DIAMETER FRAMES

One efficiency curve is shown for each stack length. Efficiencies for the DPBV and TENV enclosures are approximately the same, so a single curve represents both. In addition, although four different winding connections are offered for each stack length, the efficiency is the same for all connections.

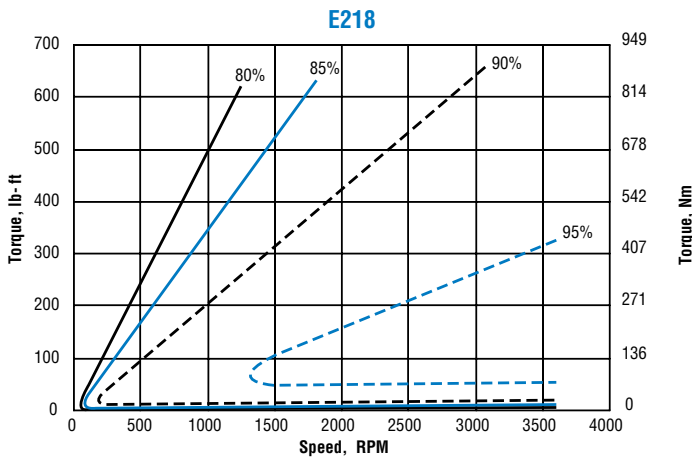
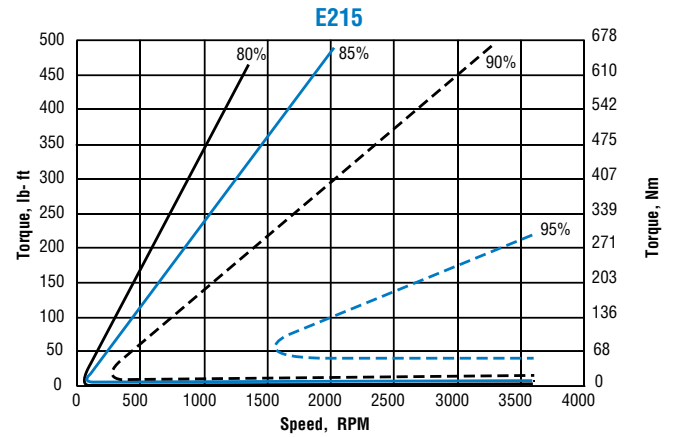
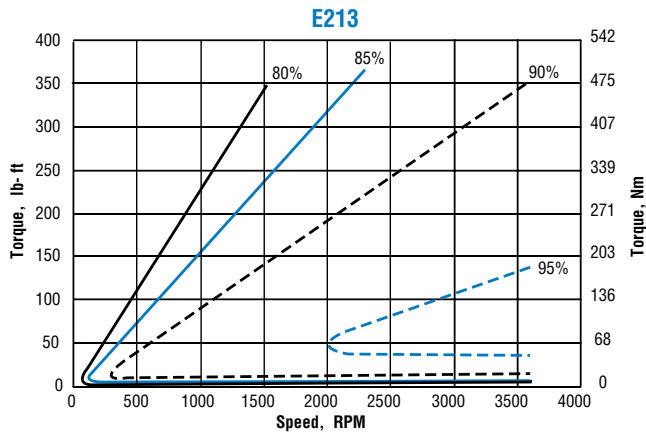

Note: see Motor Performance Curves, page 76.