

# E320 DIAMETER FRAMES

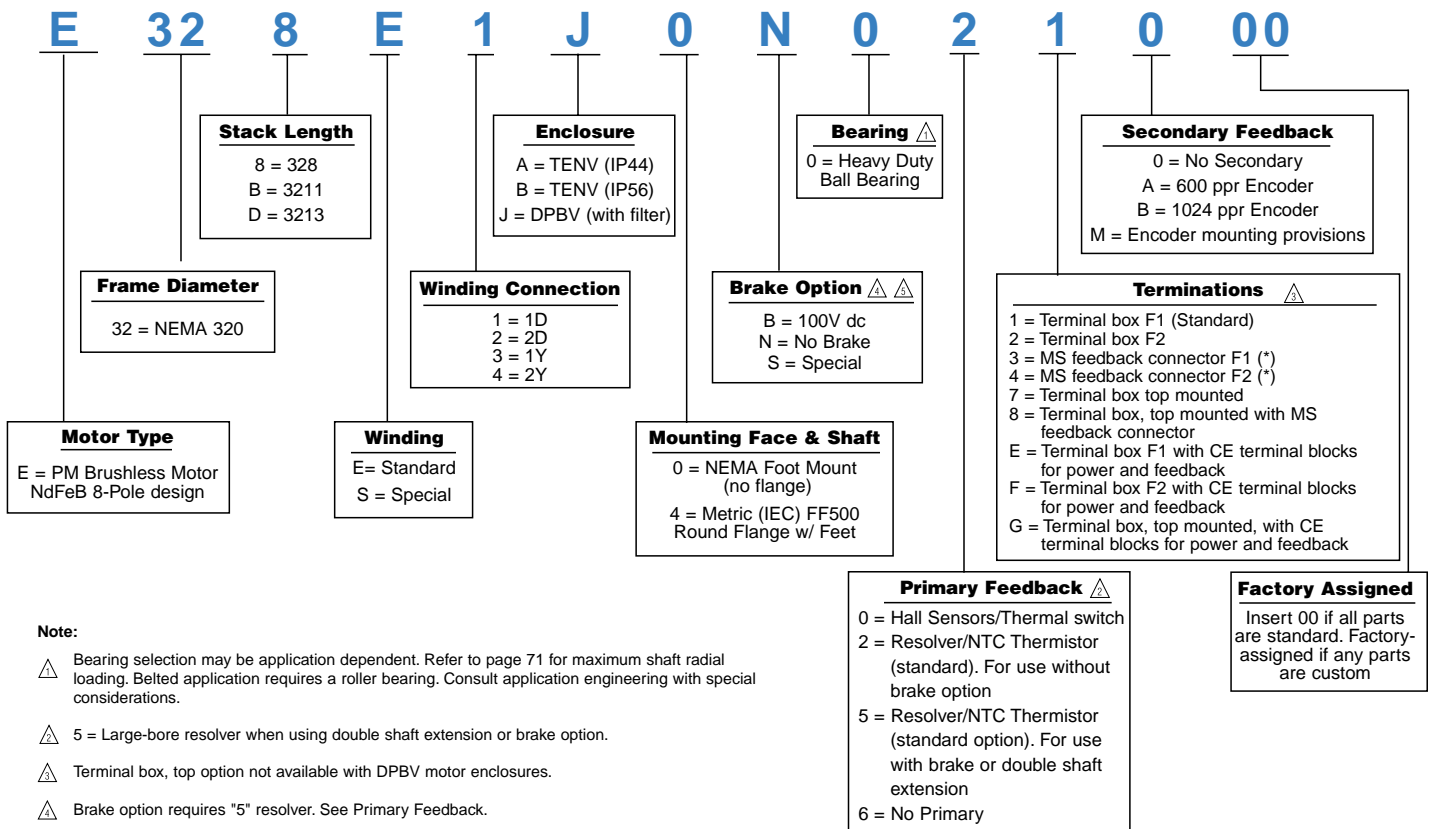

## MODEL NUMBER CODE...E320 FRAME

To construct a motor listing, select the combination of features required, and put all the coded information in the proper sequence. Please account for all the entries. The model number shown is an example of a properly specified motor.



**Note:**

- ⚠ Bearing selection may be application dependent. Refer to page 71 for maximum shaft radial loading. Belted application requires a roller bearing. Consult application engineering with special considerations.
- ⚠ 5 = Large-bore resolver when using double shaft extension or brake option.
- ⚠ Terminal box, top option not available with DPBV motor enclosures.
- ⚠ Brake option requires "5" resolver. See Primary Feedback.
- ⚠ See page 68 for a detailed list of special options.

(\*) 3,4,8: Terminal block mounted in terminal box for motor power and MS connector for feedback.

# E320 DIAMETER FRAMES



## RATINGS AND CHARACTERISTICS

Motor parameters and winding data

### ENGLISH

### METRIC

Parameters, DPBV & TENV	Symbol	Units	E328	E32B	E32D	Symbol	Units	328	E32B	E32D
Continuous stall torque $\Delta \Delta$	$T_{CS}$	lb-ft	900 (440)	1089 (530)	1367 (680)	$T_{CS}$	Nm	1220 (596)	1476 (718)	1852 (921)
Peak Torque (theoretical) $\Delta$	$T_{PK}$	lb-ft	1955	2276	2982	$T_{PK}$	Nm	2649	3084	4041
Inertia (motor only)	$J_M$	lb-ft-sec <sup>2</sup>	.437	.513	.664	$J_M$	kgm <sup>2</sup> x 10 <sup>-3</sup>	593	696	900
Static friction (max.)	$T_f$	lb-ft	3.3	3.4	3.5	$T_f$	Nm	4.5	4.6	4.7
Viscous Damping coefficient $\Delta$	$K_{DV}$	lb-ft/Krpm	4.73	5.69	7.60	$K_{DV}$	Nm/Krpm	6.4	7.7	10.3
Thermal resistance $\Delta$	$R_{TH}$	°C/Watt	.012 (.048)	.010 (.042)	.0095 (.038)	$R_{TH}$	°C/Watt	.012 (.048)	.010 (.042)	.0095 (.038)
Thermal time constant $\Delta$	$\tau_{TH}$	min.	46 (180)	45 (190)	52 (200)	$\tau_{TH}$	min.	46 (180)	45 (190)	52 (200)
Weight $\Delta$	$W$	lbs.	842 (785)	993 (936)	1227 (1170)	$M$ (mass)	kg	383 (357)	451 (425)	558 (532)

Winding data	Symbol	Units	E328				E32B				E32D			
			E1	E2	E3	E4	E1	E2	E3	E4	E1	E2	E3	E4
Torque Constant line-line $\Delta$	$K_T$ rms	lb-ft/A Nm/A	6.41 8.69	3.21 4.35	11.10 15.05	5.55 7.53	5.92 8.03	2.96 4.01	10.25 13.90	5.13 6.95	5.92 8.03	2.96 4.01	10.25 13.90	5.13 6.95
Voltage Constant line-line $\Delta$	$K_E$ rms	V/Krpm V/rad/sec	526 5.02	263 2.51	911 8.70	456 4.35	486 4.64	243 2.32	842 8.04	421 4.02	485 4.63	243 2.32	840 8.02	420 4.01
Continuous stall current $\Delta \Delta \Delta$	$I_{CS}$	A	156(76)	315(154)	93.6(44)	182(89)	204(99)	408(199)	117(57)	235(114)	256(127)	522(260)	148(74)	296(147)
Current at peak torque $\Delta \Delta$	$I_{PK}$	A	308	617	178	356	385	769	222	444	513	1025	296	592
Hot Resistance line-line $\Delta$	$R_H$	Ohms	0.213	0.054	0.642	0.161	0.147	0.036	0.441	0.110	0.099	0.025	0.296	0.074
Cold Resistance line-line $\Delta$	$R_C$	Ohms	0.147	0.037	0.442	0.111	0.101	0.025	0.304	0.076	0.068	0.017	0.204	0.051
Inductance line-line	$L$	mH	4.363	1.091	13.09	3.273	3.372	0.843	10.12	2.529	2.518	0.629	7.553	1.888
Electrical time constant $\Delta$	$\tau_e$	msec	29.6	29.5	29.5	29.5	33.3	33.3	33.3	33.3	37.4	37.4	37.4	37.4
Mechanical time constant $\Delta$	$\tau_m$	msec	1.77	1.77	1.77	1.77	1.64	1.64	1.64	1.64	1.42	1.42	1.42	1.42
Rated base speed $\Delta$	$\omega_r$	rpm	850	1750	500	1000	850	1750	500	1000	850	1750	500	1000
Rated current @ rated speed, RMS Amperes	$I_R$	A	156 (66)	286 (N/A)	92 (43)	178 (71)	195 (81)	357 (N/A)	116 (53)	223 (86)	242 (100)	435 (N/A)	144 (67)	276 (105)
Power @ rated speed $\Delta$	$P_R$	HP, DPBV (TENV)	139 (58)	263 (N/A)	84 (38)	162 (63)	168 (68)	315 (N/A)	101 (45)	195 (74)	209 (84)	384 (N/A)	127 (58)	242 (90)
Power @ rated speed $\Delta$	$P_R$	kW, DPBV (TENV)	103.7 (43.3)	196.2 (N/A)	62.7 (28.3)	120.9 (47.0)	125 (50.7)	235 (N/A)	75.3 (33.6)	195.5 (55.2)	156.0 (62.7)	286.5 (N/A)	94.7 (43.3)	180.5 (67.1)

Note: All values at 40°C unless otherwise noted.

- $\Delta$  25°C ambient temperature
- $\Delta$  ( ) denotes TENV when dual ratings are shown. Single ratings apply to both
- $\Delta$  Based on RMS (sine wave) amps
- $\Delta$  140°C winding temperature
- $\Delta$  640V dc
- $\Delta$  Theoretical (cold) ratings at peak current,  $I_{PK}$ . For ratings at rated temperature, see Torque-Speed curves, pages 51-53
- $\Delta$  Demagnetization current for 150°C magnet temperature

# DIMENSIONS ... E320 Diameter Frames; DPBV (Dripproof, Blower Ventilated)

## FRONT VIEW

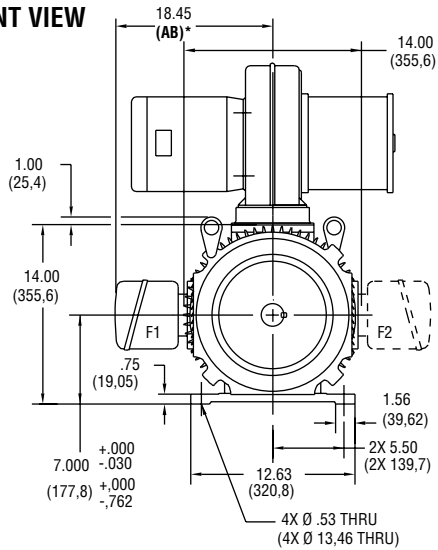

## SIDE VIEW

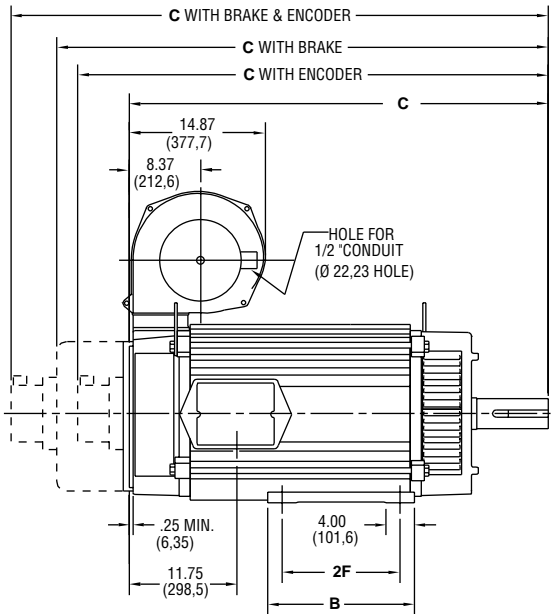

CALLOUT FOR "C" DIMENSION				
MODEL	MOTOR ONLY	WITH ENCODER	WITH BRAKE	WITH BRAKE & ENCODER
E328	44.33 (1126)	47.12 (1196,8)	52.09 (1323,1)	54.06 (1373,1)
E32B	51.08 (1297,4)	53.87 (1368,3)	58.54 (1494,5)	60.81 (1544,6)
E32D	57.83 (1468,9)	60.62 (1539,7)	65.59 (1666)	67.56 (1716)

MODEL	2F DIMENSION	B DIMENSION
E328	16.00 (406,4)	17.88 (454,2)
E32B	22.00 (558,8)	23.88 (607)
E32D	28.00 (711,2)	29.88 (759)

Dimensions in ( ) are mm, all others in inches

## REAR VIEW

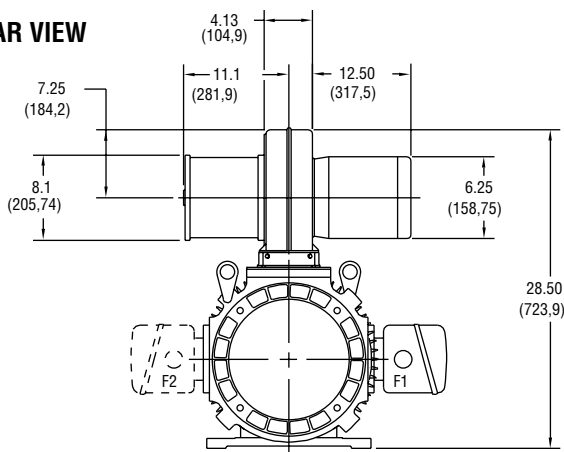

### NOTE:

1. Reference pages 56, 57 for conduit box dimensions.
2. Conduit box can be rotated in 90° steps on its own axis and can be mounted on opposite side or top when specified.
3. Blower can be rotated 180° about its axis. Size #10 blower is used on E320 frames. See page 67.

\* See terminations, page 56.

# DIMENSIONS . . . E320 Diameter Frames; TENV (Totally Enclosed, Non-Ventilated)

## FRONT VIEW

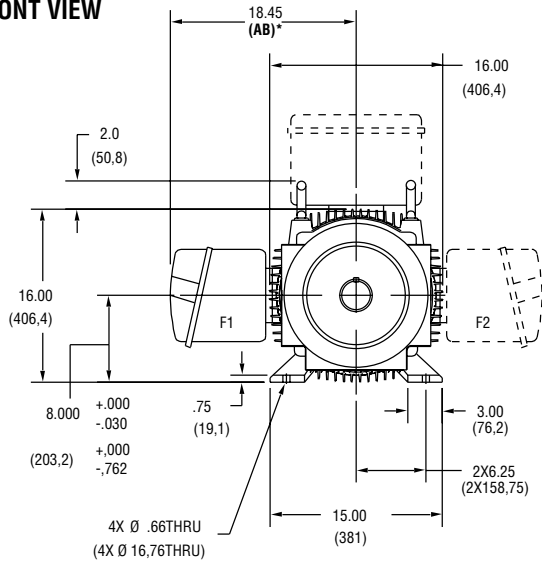

## SIDE VIEW

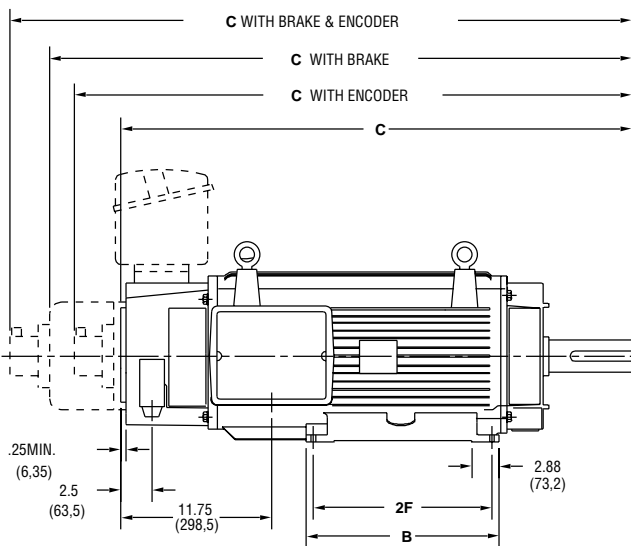

CALLOUT FOR "C" DIMENSION				
MODEL	MOTOR ONLY	WITH ENCODER	WITH BRAKE	WITH BRAKE & ENCODER
E328	44.33 (1126)	47.12 (1196,8)	52.09 (1323,1)	54.06 (1373,1)
E32B	51.08 (1297,4)	53.87 (1368,3)	58.54 (1494,5)	60.81 (1544,6)
E32D	57.83 (1468,9)	60.62 (1539,7)	65.59 (1666)	67.56 (1716)

MODEL	2F DIMENSION	B DIMENSION
E328	16.00 (406,4)	17.88 (454,2)
E32B	22.00 (558,8)	23.88 (607)
E32D	28.00 (711,2)	29.88 (759)

Dimensions in ( ) are mm, all others in inches

## REAR VIEW

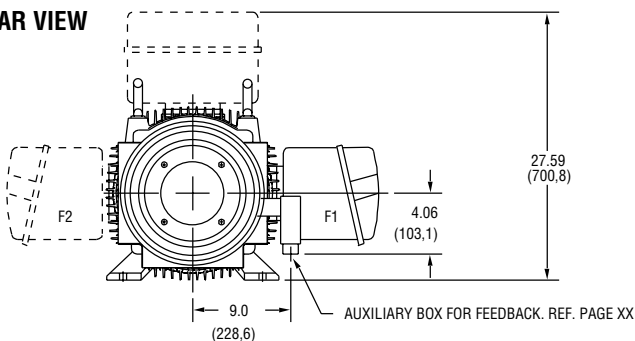

### NOTE:

- Reference pages 56, 57 for conduit box dimensions.
- Conduit box can be rotated in 90° steps on its own axis and can be mounted on opposite side or top when specified.

\* See terminations, page 56.

# DIMENSIONS . . . 320 Diameter Frame Mounting; NEMA and Metric

## NEMA FOOT MOUNT

Dimensions in inches

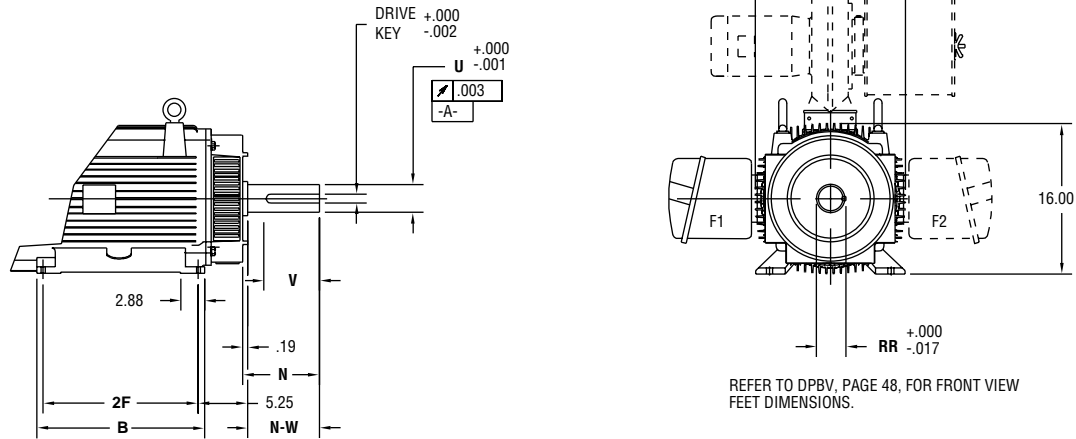

MODEL	2F	B	N	N-W	U	V	RR	Drive Key
E328	16.00	17.88	5.94	5.75	2.875	5.25	3.200	.750
E32B	22.00	23.88	6.69	6.50	3.250	6.00	3.581	.750
E32D	28.00	29.88	7.44	7.25	3.625	6.75	4.009	.875

SHAFT DIMENSIONS FOR BELT DUTY						
MODEL	N	N-W	U	V	RR	Drive Key
E328	6.69	6.50	3.250	6.00	3.581	.750
E32B	7.44	7.25	3.625	6.75	4.009	.875
E32D	8.44	8.25	4.125	7.75	4.563	1.000

## ALTERNATE MOUNTING

Metric (IEC) FF265

Dimensions in mm

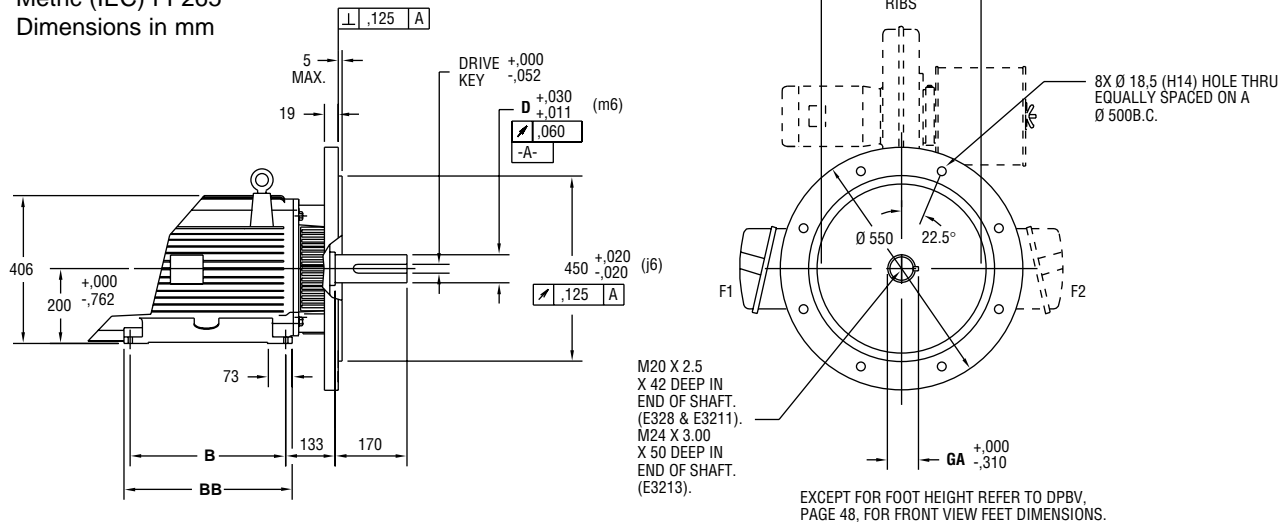

MODEL	D	B	BB	GA	Drive Key
E328	80	406,4	454	85	22
E32B	80	558,8	607	85	22
E32D	90	711,2	759	95	25

# PERFORMANCE CURVES

## 320 FRAME E328

### Test Conditions

- Motor operated in ambient temperature of 40° C maximum that results in a maximum motor stator winding temperature of 140° C
- 640V dc bus applied
- Sinusoidal drive output

- Intermittent duty
- Continuous duty

### DPBV DRIPPROOF BLOWER VENTILATED

### TENV TOTALLY ENCLOSED NON-VENTILATED

#### E328E3 MOTOR

Reference Points	
$T_{PK}$	1700
$T_{CS}$	900
$T_{CR}$	880
$W_R$	500
$I_{CS}$	94.0
$I_{CR}$	92.0

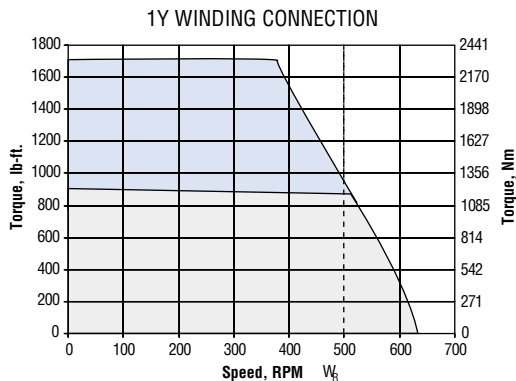

#### E328E3 MOTOR

Reference Points	
$T_{PK}$	1700
$T_{CS}$	440
$T_{CR}$	400
$W_R$	500
$I_{CS}$	44.0
$I_{CR}$	43.0

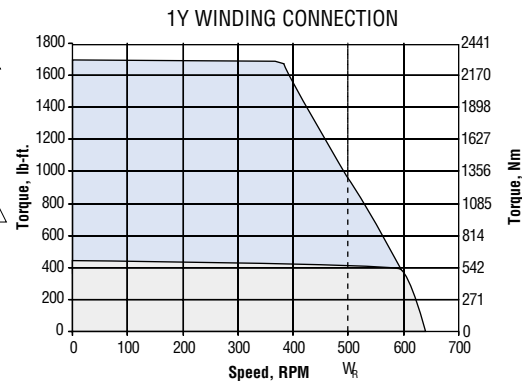

#### E328E1 MOTOR

Reference Points	
$T_{PK}$	1700
$T_{CS}$	900
$T_{CR}$	860
$W_R$	850
$I_{CS}$	156.0
$I_{CR}$	156.0

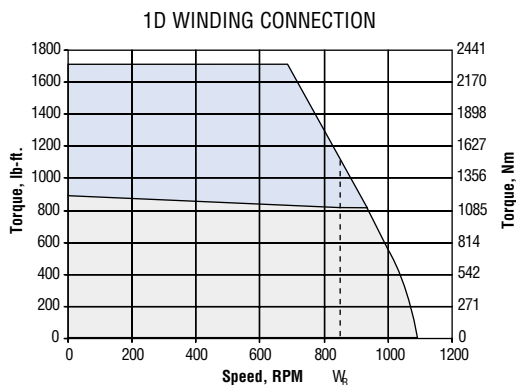

#### E328E1 MOTOR

Reference Points	
$T_{PK}$	1700
$T_{CS}$	440
$T_{CR}$	356
$W_R$	850
$I_{CS}$	76.0
$I_{CR}$	66.0

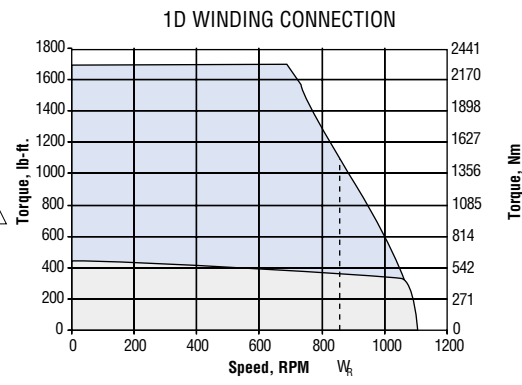

#### E328E4 MOTOR

Reference Points	
$T_{PK}$	1700
$T_{CS}$	900
$T_{CR}$	850
$W_R$	1000
$I_{CS}$	182
$I_{CR}$	178

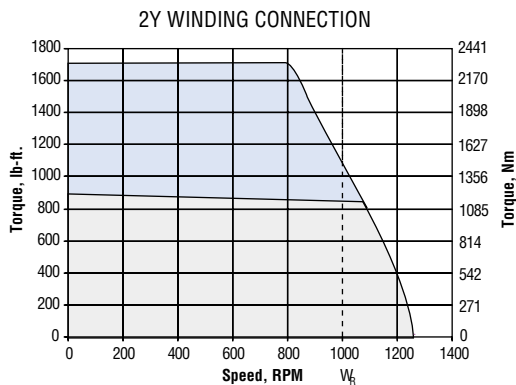

#### E328E4 MOTOR

Reference Points	
$T_{PK}$	1700
$T_{CS}$	440
$T_{CR}$	333
$W_R$	1,000
$I_{CS}$	89.0
$I_{CR}$	71.0

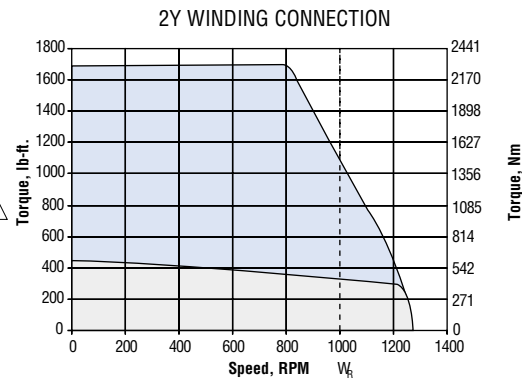

#### E328E2 MOTOR

Reference Points	
$T_{PK}$	1700
$T_{CS}$	900
$T_{CR}$	789
$W_R$	1750
$I_{CS}$	315
$I_{CR}$	286

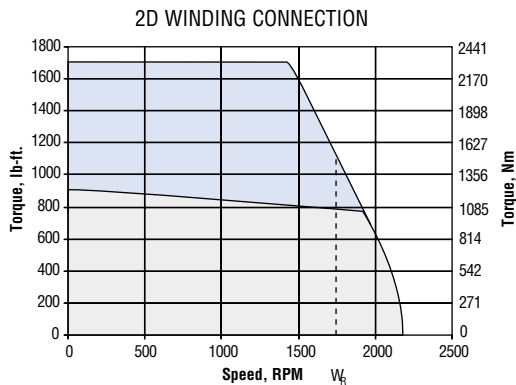

#### E328E2 MOTOR

Reference Points	
$T_{PK}$	1700
$T_{CS}$	440
$T_{CR}$	137
$W_R$	-
$I_{CS}$	154
$I_{CR}$	-

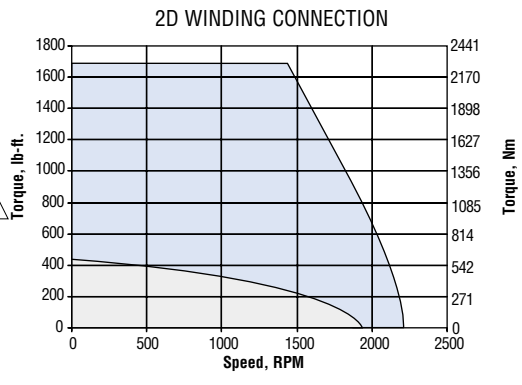

- △ See model number code, page 46.
- △ This is also the demagnetization limit. User should apply appropriate safety margins in its use.

- Notes:
1. See Motor Performance Curves, page 76.
  2. See Thermal Protection, page 69.
  3. See Power Curves, page 54.
  4. See Efficiency Curves, page 55.

# PERFORMANCE CURVES

## 320 FRAME E32B

Intermittent duty  
 Continuous duty

### Test Conditions

- Motor operated in ambient temperature of 40° C maximum that results in a maximum motor stator winding temperature of 140° C
- 640V dc bus applied
- Sinusoidal drive output
- 2Y & 2D windings suitable for use with dual drives

**DPBV**  
**DRIPPROOF**  
**BLOWER VENTILATED**

**TENV**  
**TOTALLY ENCLOSED**  
**NON-VENTILATED**

### E32BE3 △ MOTOR

Reference Points	
$T_{PK}$	2050
$T_{CS}$	1090
$T_{CR}$	1063
$W_R$	500
$I_{CS}$	117.0
$I_{CR}$	116.0

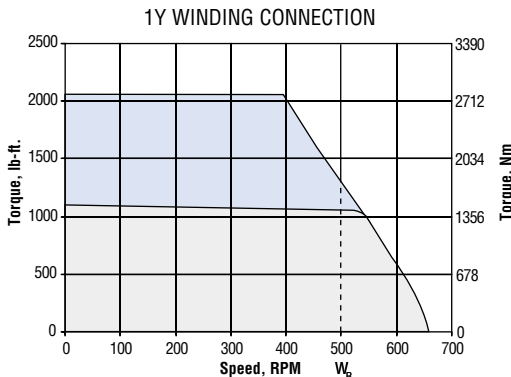

### E32BE3 △ MOTOR

Reference Points	
$T_{PK}$	2050
$T_{CS}$	530
$T_{CR}$	477
$W_R$	500
$I_{CS}$	57.0
$I_{CR}$	53.0

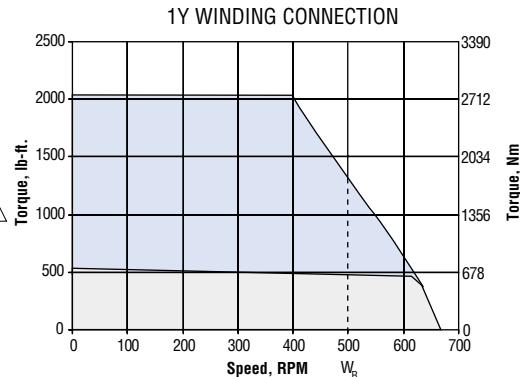

### E32BE1 △ MOTOR

Reference Points	
$T_{PK}$	2050
$T_{CS}$	1090
$T_{CR}$	1036
$W_R$	850
$I_{CS}$	204
$I_{CR}$	195

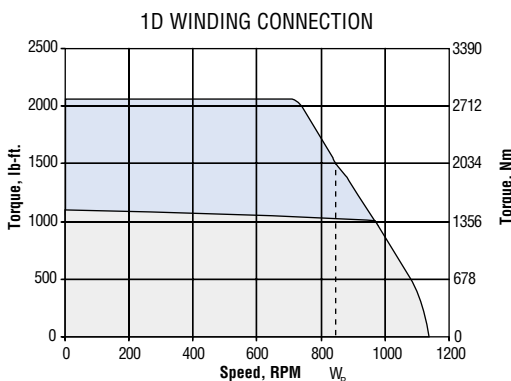

### E32BE1 △ MOTOR

Reference Points	
$T_{PK}$	2050
$T_{CS}$	530
$T_{CR}$	418
$W_R$	850
$I_{CS}$	99.0
$I_{CR}$	81.0

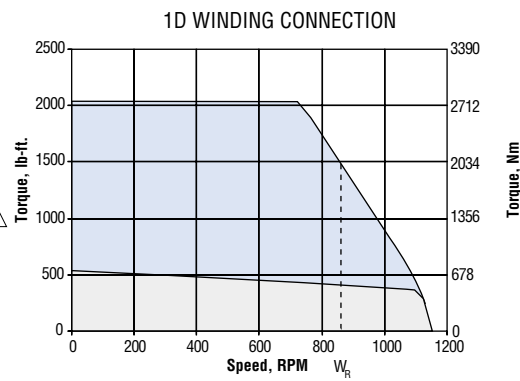

### E32BE4 △ MOTOR

Reference Points	
$T_{PK}$	2050
$T_{CS}$	1090
$T_{CR}$	1023
$W_R$	1,000
$I_{CS}$	235.0
$I_{CR}$	223.0

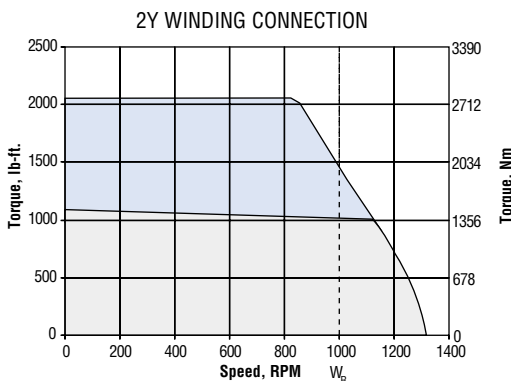

### E32BE4 △ MOTOR

Reference Points	
$T_{PK}$	2050
$T_{CS}$	530
$T_{CR}$	387
$W_R$	1000
$I_{CS}$	114
$I_{CR}$	86.0

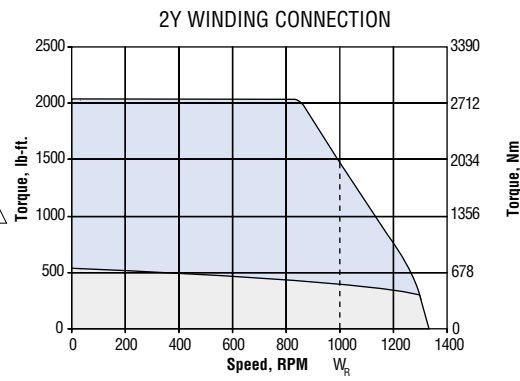

### E32BE2 △ MOTOR

Reference Points	
$T_{PK}$	2050
$T_{CS}$	1090
$T_{CR}$	943
$W_R$	1750
$I_{CS}$	408
$I_{CR}$	357

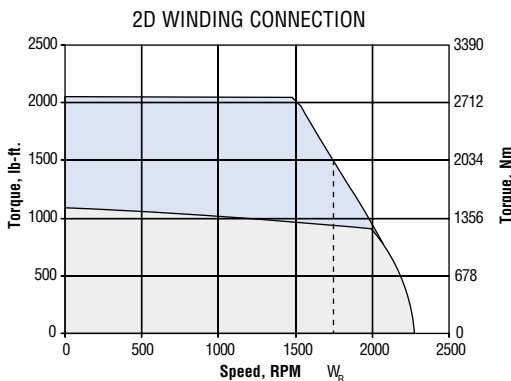

### E32BE2 △ MOTOR

Reference Points	
$T_{PK}$	2050
$T_{CS}$	530
$T_{CR}$	79
$W_R$	-
$I_{CS}$	199
$I_{CR}$	-

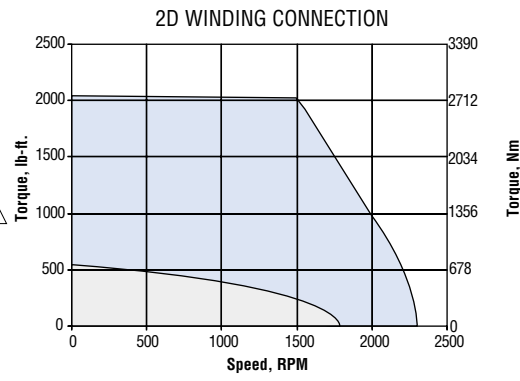

- △ See model number code, page 46.
- △ This is also the demagnetization limit. User should apply appropriate safety margins in its use.

- Notes:
1. See Motor Performance Curves, page 76.
  2. See Thermal Protection, page 69.
  3. See Power Curves, page 54.
  4. See Efficiency Curves, page 55.

# PERFORMANCE CURVES

## 320 FRAME E32D

Intermittent duty  
 Continuous duty

### Test Conditions

- Motor operated in ambient temperature of 40° C maximum that results in a maximum motor stator winding temperature of 140° C
- 640V dc bus applied
- Sinusoidal drive output
- 2Y & 2D windings suitable for use with dual drives

**DPBV**  
**DRIPPROOF**  
**BLOWER VENTILATED**

**TENV**  
**TOTALLY ENCLOSED**  
**NON-VENTILATED**

### E32DE3 MOTOR

Reference Points	
$T_{PK}$	2730
$T_{CS}$	1368
$T_{CR}$	1329
$W_R$	500
$I_{CS}$	148.0
$I_{CR}$	144.0

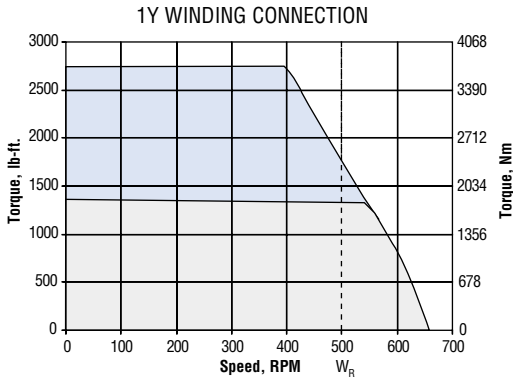

### E32DE3 MOTOR

Reference Points	
$T_{PK}$	2730
$T_{CS}$	680
$T_{CR}$	605
$W_R$	500
$I_{CS}$	74.0
$I_{CR}$	67.0

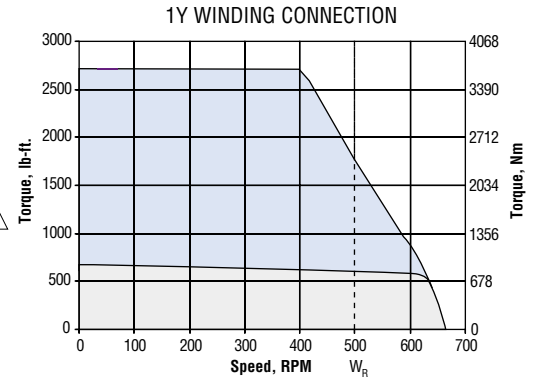

### E32DE1 MOTOR

Reference Points	
$T_{PK}$	2730
$T_{CS}$	1368
$T_{CR}$	1290
$W_R$	850
$I_{CS}$	256.0
$I_{CR}$	243.0

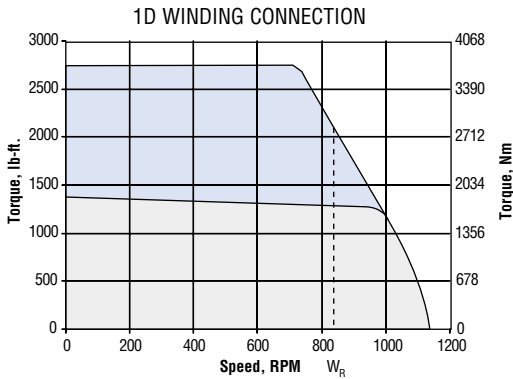

### E32DE1 MOTOR

Reference Points	
$T_{PK}$	2730
$T_{CS}$	680
$T_{CR}$	520
$W_R$	850
$I_{CS}$	127.0
$I_{CR}$	100.0

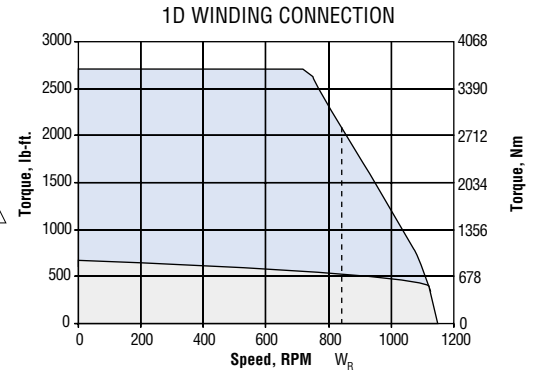

### E32DE4 MOTOR

Reference Points	
$T_{PK}$	2730
$T_{CS}$	1368
$T_{CR}$	1240
$W_R$	1000
$I_{CS}$	296.0
$I_{CR}$	276.0



### E32DE4 MOTOR

Reference Points	
$T_{PK}$	2730
$T_{CS}$	680
$T_{CR}$	473
$W_R$	1000
$I_{CS}$	147
$I_{CR}$	106

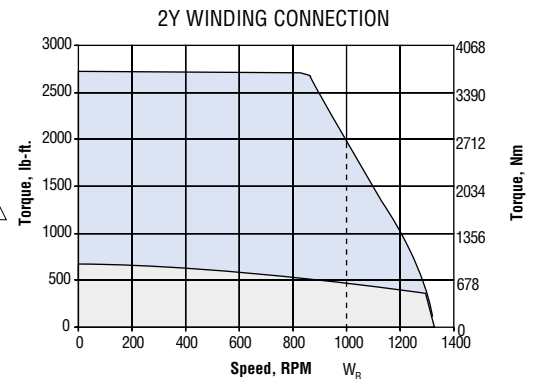

### E32DE2 MOTOR

Reference Points	
$T_{PK}$	2730
$T_{CS}$	1368
$T_{CR}$	1152
$W_R$	1750
$I_{CS}$	522
$I_{CR}$	435

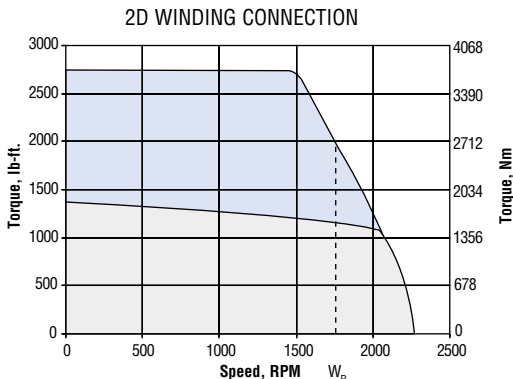

### E32DE2 MOTOR

Reference Points	
$T_{PK}$	2730
$T_{CS}$	680
$T_{CR}$	-
$W_R$	-
$I_{CS}$	260
$I_{CR}$	-

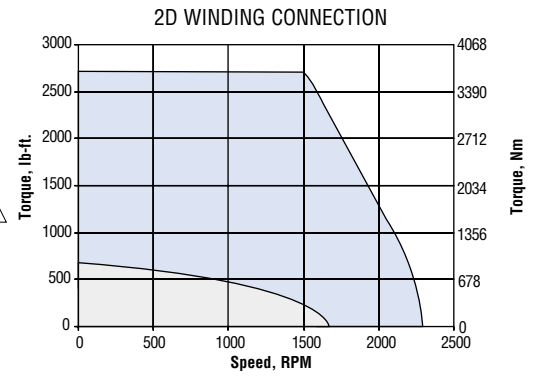

- △ See model number code, page 46.
- △ This is also the demagnetization limit. User should apply appropriate safety margins in its use.

- Notes:
1. See Motor Performance Curves, page 76.
  2. See Thermal Protection, page 69.
  3. See Power Curves, page 54.
  4. See Efficiency Curves, page 55.

# CONTINUOUS POWER CURVES

## E320 DIAMETER FRAMES

Standard E320 frame motors are limited (mechanical design) to 3000 RPM. Special designs are available that allow operation to speeds indicated in the individual curves.

One power curve is shown for each stack length in both the DPBV and TENV enclosures. Four different winding connections are offered for each stack length, but the power curve is the same for all connections. Therefore, only one power curve is necessary for each stack length and enclosure.

### DPBV DRIPPROOF BLOWER VENTILATED

### TENV TOTALLY ENCLOSED NON-VENTILATED

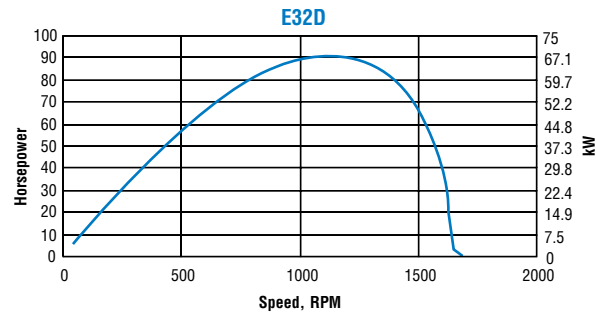
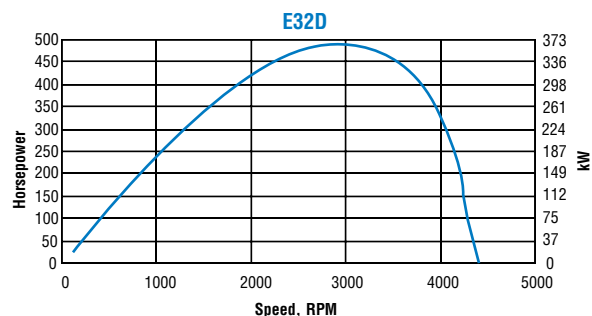
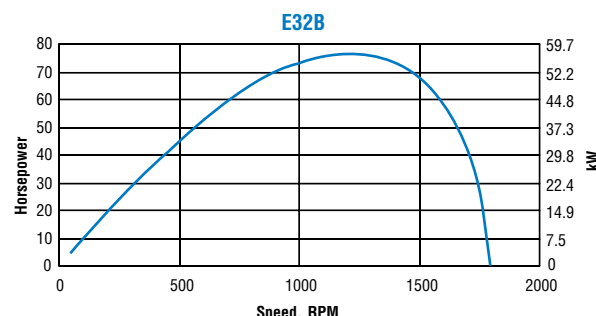
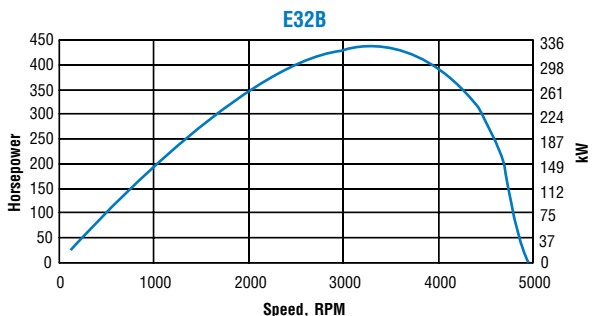
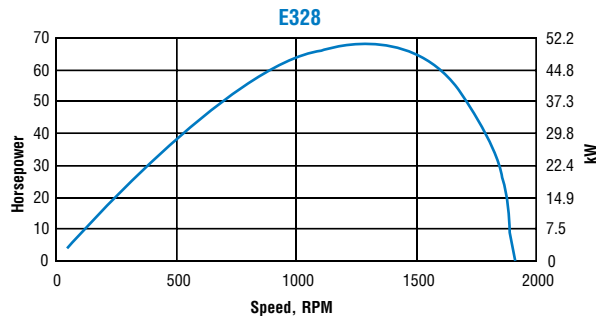
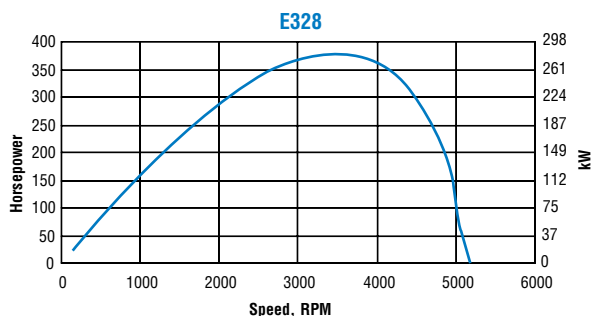

Note: see Motor Performance Curves, page 76.

# EFFICIENCY CURVES

## E320 DIAMETER FRAMES

One efficiency curve is shown for each stack length. Efficiencies for the DPBV and TENV enclosures are approximately the same, so a single curve represents both. In addition, although four different winding connections are offered for each stack length, the efficiency is the same for all connections.

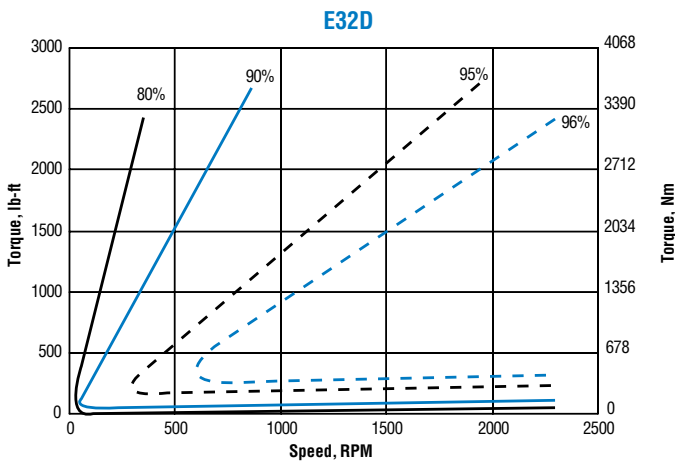
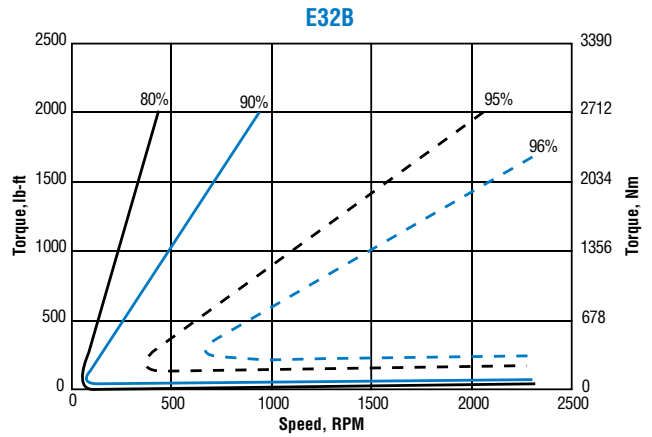
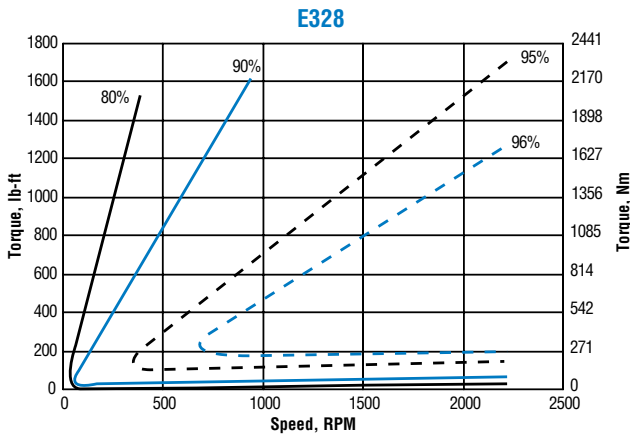

Note: see Motor Performance Curves, page 76.