

DRIVES INDEX

How to use this section

This section covers our extensive line of high performance GENESIS and MILLENNIUM Series Brushless DC Drives. Select the proper drive using one of the following procedures.

- If you are already familiar with these drives and the available options, refer to the GENESIS Model Number Codes beginning on page 81, or the MILLENNIUM Model Number Codes beginning on page 95 to verify the coded information.
- If you are not familiar with these drives and the available options refer to the GENESIS general specifications on page 80, the MILLENNIUM general specifications on page 94 and/or the index at the right. Construct a model number after all the technical parameters, including options, are determined.

GENESIS Series Brushless DC Drives

Product Overview	78
Features and Benefits	79
Product Description	80
Typical Applications	80
Available Options	80
Agency Approvals	80
Model Number Codes (Model 500-4000)	81
Pricing	84
Dimensions and Weights	87
Typical Connection Diagrams	88
Efficiency Ratings	89
Technical Specifications	90
Bus Loaders	91

MILLENNIUM® Series Brushless DC Drives

Product Overview	92
Features and Benefits	93
Product Description	94
Typical Applications	94
Available Options	94
Model Number Codes (M4-M7)	95
Pricing	97
Dimensions and Weights	99
Typical Connection Diagrams	100
Application Templates and Efficiency Ratings	101
Technical Specifications	102

Drive Options Boards	103
----------------------	-----

Drive Option Kits	105
-------------------	-----

Drive Accessories	105
-------------------	-----

Dynamic Braking Kits	106
----------------------	-----

A

MOTORS

B

DRIVES

C

PRE-ENGINEERED
DRIVE SYSTEMS

D

GENERAL
INFORMATION

GENESIS SERIES BRUSHLESS DC DRIVES

The Genesis Series Brushless DC Drive Family is constructed on a digital platform employing an analog user interface. This interface includes potentiometer adjustable gain, stability, current limit, acceleration, deceleration, jog speed, max speed, and min speed. Run speed is controlled using either an external potentiometer or a digital pulse train input.

With precise speed control and high torque at low speeds, the Genesis Series Drive Family provides servo-like response in a highly efficient and affordable package.

Simple Set-Up

The Genesis Series Brushless DC Drive Family was designed for easy configuration to your application. Set-up is completed in a matter of minutes by adjusting a few potentiometers to tailor the drive performance. The interface is clearly labeled and easily accessed on the speed controller board.

Precision Control

The Genesis Series Drive employs electromechanical Hall Sensor Feedback for motor commutation. Using an analog or digital pulse train speed input, the Hall Sensor Feedback circuitry provides for 0% Speed Regulation with a Constant Torque Speed Range of 100:1 or better.

Low Power Consumption

The Genesis Series Drive has a near unity power factor at all motor speeds and loads. The bottom transistors of the six-transistor power stage are controlled with pulse width modulation. Utilizing this design, the Genesis Series Drive draws only enough input current to provide torque to the motor.

Easy Maintenance

The same Speed Controller Board and Current Controller Board are used in the Genesis Series 1000, 2000, 3000, 3500, and 4000 Drives. These boards are readily accessible, easily connected, and simple to configure. This Family approach to the Genesis Series Drives means smaller spare parts stock and added familiarity with the board-level operations of the drive family.



GENESIS SERIES BRUSHLESS DC DRIVES

FEATURES

Two or four quadrant operation

Input AC line fusing

DC link choke

Separately adjustable min/max speed control, accel/decel time

Adjustable gain, stability, current limit, and jog speed

Bi-directional jog function

Analog speed input 0 to +10 VDC

Electronic gearing

Motor speed frequency output

Analog load output
(optional on some models)

Run relay output
(optional on Model 500)

Fault and zero speed open collector outputs

0% speed regulation

Constant Torque Speed Range (CTSR), 100:1

Standard two year warranty

BENEFITS

Excellent control for both regenerative and non-regenerative applications

Fast acting fusing provides very high interrupting capacity for ground or short circuits within or after the control input

Line transient protection limits the rate of change in the input current

Precise configuration to your application

Precise configuration to your application

Jog function operates in both forward and reverse in accordance with the forward/reverse input

Provides internal supply for analog speed pot operation or accepts 0 to +10 VDC external reference

Provides uni-directional digital follower mode

Open collector frequency output for metering or electronic gearing in a lead/follower system

Analog signal for metering represents 150% of output current or torque

External run contact for customer use: 125 VAC @ 1A or 30 VDC @ 2A

Digital outputs to indicate fault or zero speed conditions

Built in speed feedback/phase lock loop control provides precise speed control

Precise speed and current regulation through the entire motor speed-torque range

Assured quality and reliability

A

MOTORS

B

DRIVES

C

PRE-ENGINEERED
DRIVE SYSTEMS

D

GENERAL
INFORMATION

GENESIS SERIES BRUSHLESS DC DRIVES



FEATURES

MODEL 500-4000

- Two- or four-quadrant operation
- Input AC line fusing
- DC link choke
- Analog speed input, 0 to +10 VDC
- External frequency speed input, 0-14 kHz
- Fault output (open collector)
- Motor speed frequency output
- 0% speed regulation
- 100:1 constant torque speed range

ADDITIONAL FEATURES

MODEL 1000-4000

- Bi-directional jog function
- Zero speed output (open collector)
- Run relay output
- Analog load output

PRODUCT DESCRIPTION

Pacific Scientific's Genesis Series Brushless DC Drives are high performance, closed loop drives designed for application flexibility. They are available as two quadrant, non-regenerative or four quadrant, resistor regenerative drives. Both configurations are offered in open chassis mountable enclosures. The Model 500 is also available in a NEMA 1 enclosure.

The Genesis Series offers slip-less speed control and full torque over its Constant Torque Speed Range of 100:1. This servo-like response makes it a good choice for applications requiring precise speed control and high torque at low speeds, with extremely high efficiency.

The Genesis Series offers such capabilities as analog or digital speed control. It also has several field-installable options that allow simple configuration to your specific applications.

TYPICAL APPLICATIONS

- Test stands
- Extruders
- Electronic line shafting
- Winders
- Pullers
- Wire drawing
- Printing
- Forest Industry machinery
- Tube and rolling mills
- Textile machinery
- Punch presses
- Paper converting

AVAILABLE OPTIONS

- Analog Interface Board
- Auxiliary Feedback Board
- Dancer Interface Board
- DC Relay Module
- Dual Ramp Accel/Decel Board
- Logic Extender Board
- Multiple Preset Speed Board
- Overspeed Board
- PID Board
- Power Supply Board
- Process Interface Board
- Signal Processor Board
- System Interface Board
- Threshold Detector Board
- Torque Controller Board
- BCDMax[®] BCD Speed Reference Input
- DigiMax[®] Digital Speed Reference Controller
- DigiTrak[®] Digital Speed and Load Display

AGENCY APPROVALS



E137798 vol. 3



C22.2 No. 142-M1987

GENESIS SERIES BRUSHLESS DC DRIVES

A

MOTORS



GENESIS MODEL 500 DRIVE

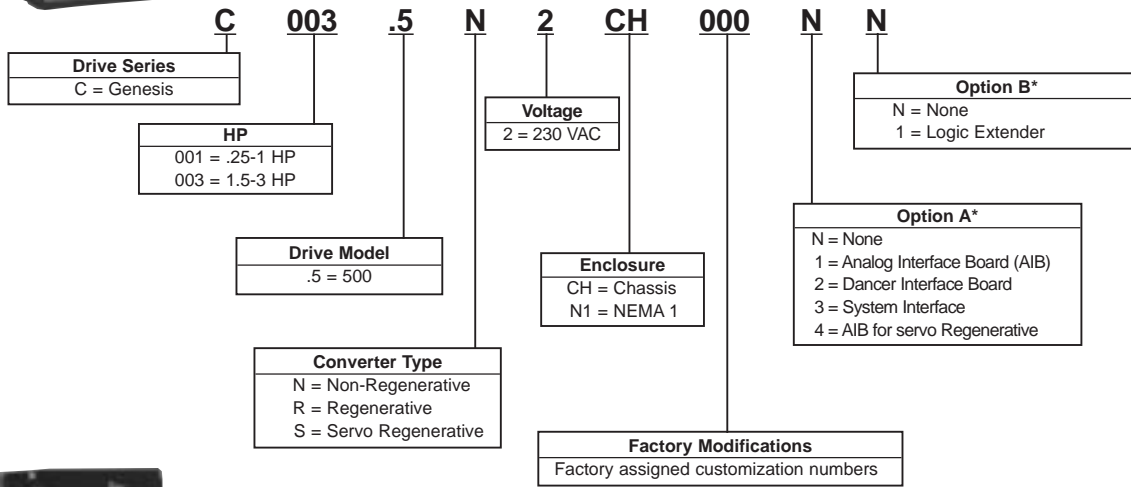

B

DRIVES



GENESIS MODEL 1000 DRIVE

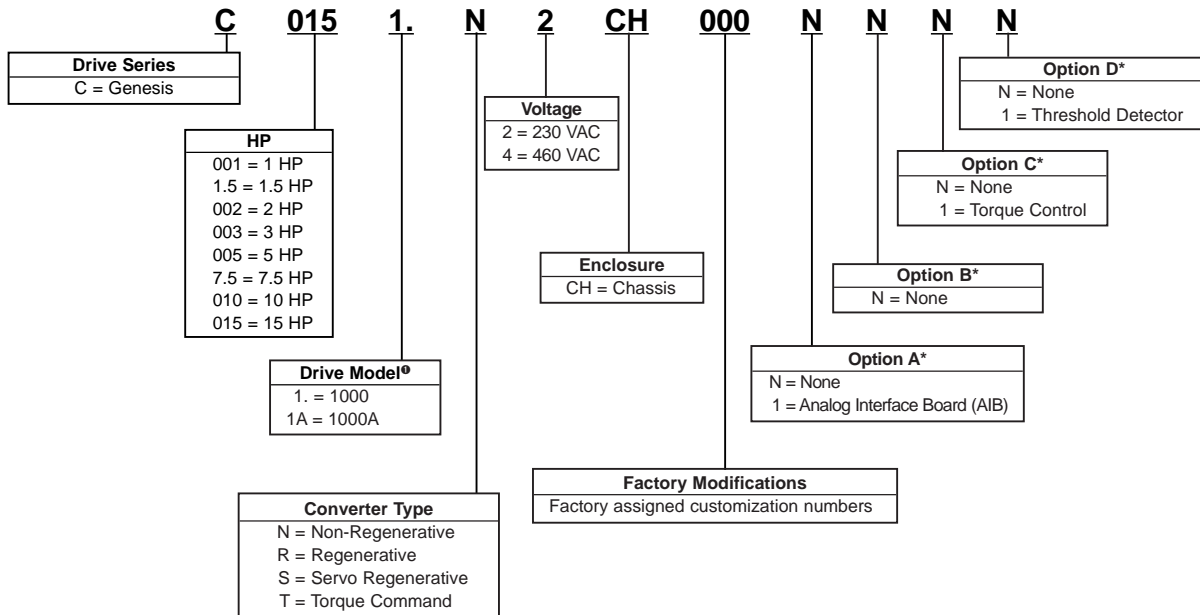

C

PRE-ENGINEERED
DRIVE SYSTEMS

D

GENERAL
INFORMATION

Ⓞ Model 1000 Drive for non-regenerative 1-10 HP only.

*For option descriptions and pricing refer to page 103.

NOTE: To construct a drive model number select the combination of features required and put all the coded information in the proper sequence. Please account for all entries. The model number shown is an example of a properly specified drive.

GENESIS SERIES BRUSHLESS DC DRIVES



GENESIS MODEL 2000 DRIVE

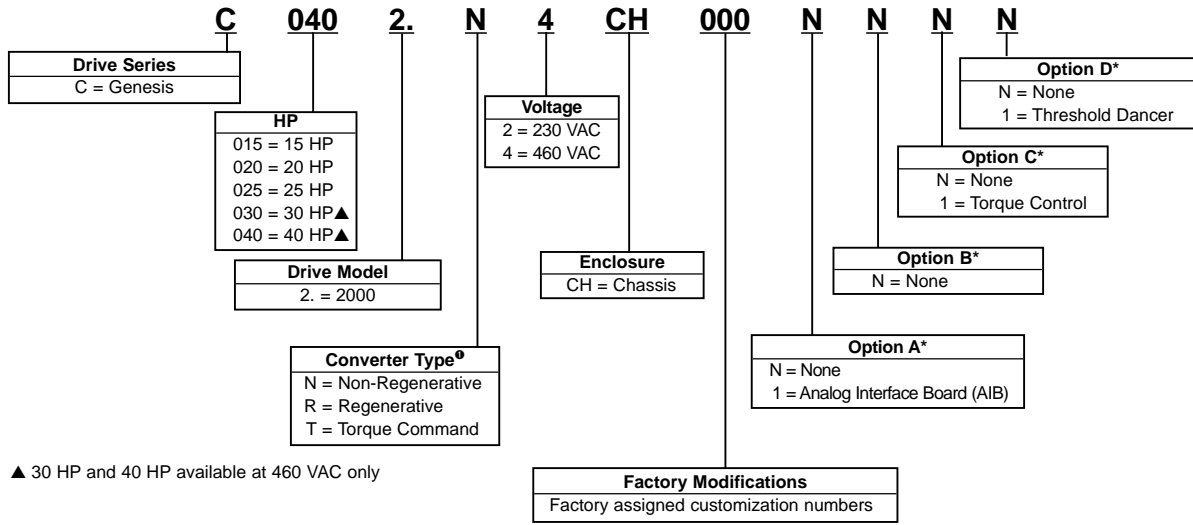

▲ 30 HP and 40 HP available at 460 VAC only



GENESIS MODEL 3000 DRIVE

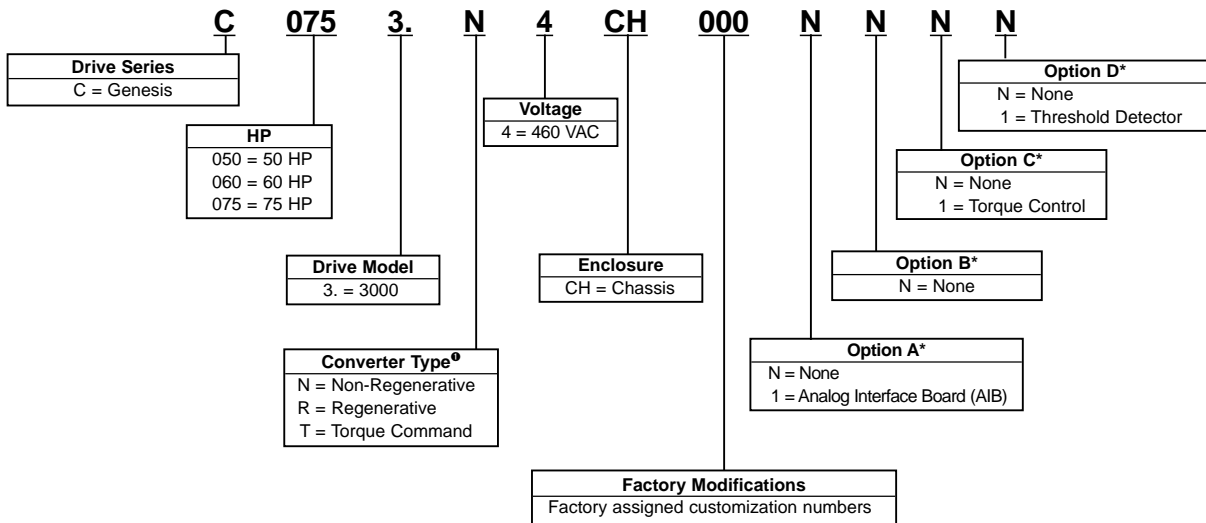

⓪ Regenerative Drives include separate Bus Loader and Resistor Cage. Refer to page 87 for dimensions.

*For option descriptions and pricing refer to page 103.

NOTE: To construct a drive part number select the combination of features required and put all the coded information in the proper sequence. Please account for all entries. The model number shown is an example of a properly specified drive.

GENESIS SERIES BRUSHLESS DC DRIVES

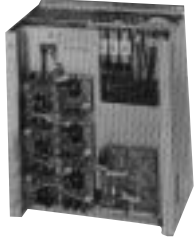

GENESIS MODEL 3500 DRIVE

A

MOTORS

B

DRIVES

C

PRE-ENGINEERED
DRIVE SYSTEMS

D

GENERAL
INFORMATION

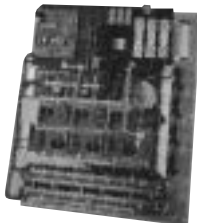
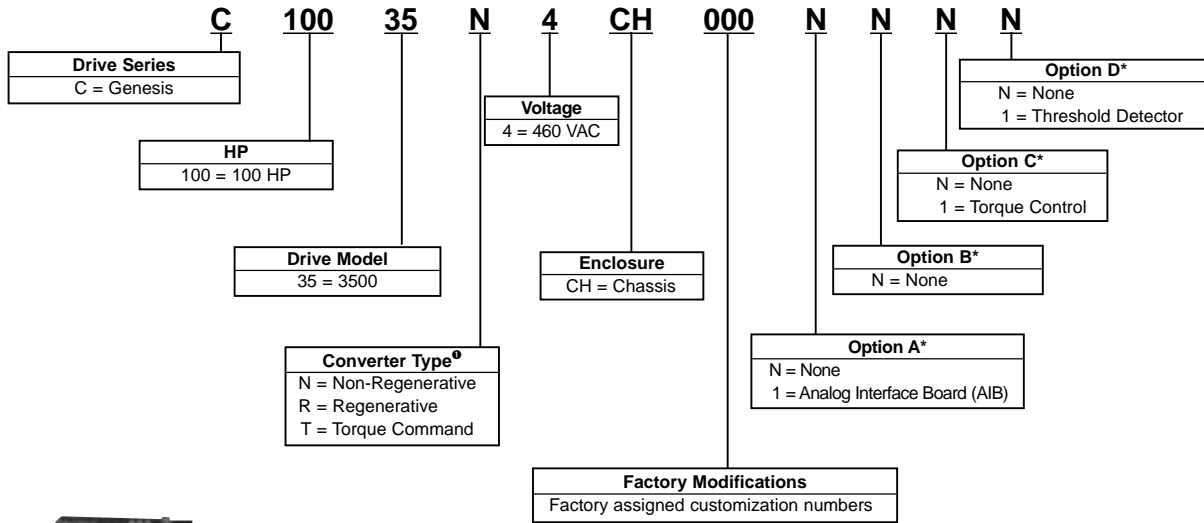

GENESIS MODEL 4000 DRIVE

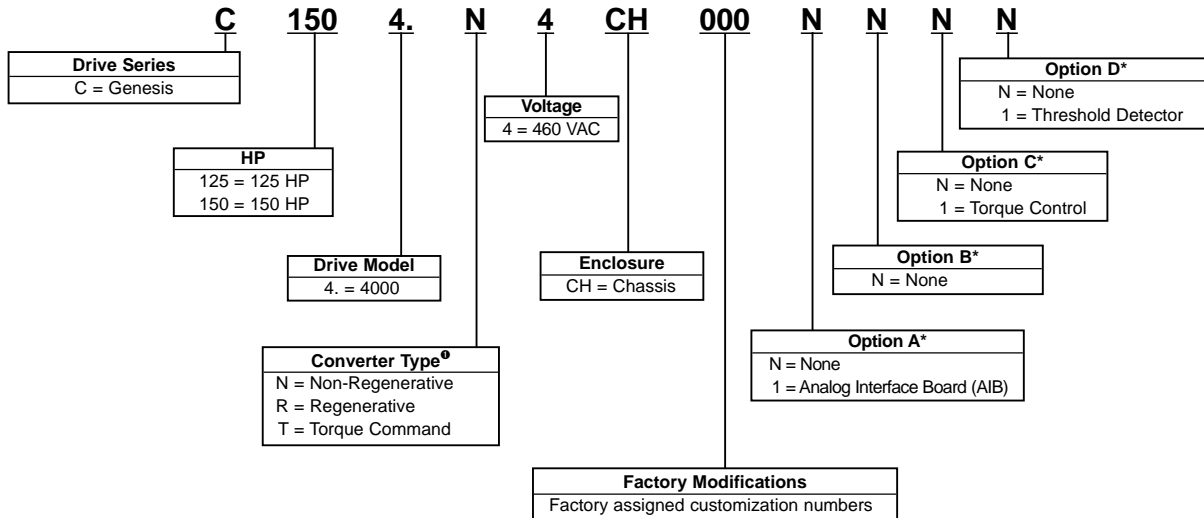

⁹ Regenerative Drives include separate Bus Loader and Resistor Cage. Refer to page 87 for dimensions.

*For option descriptions and pricing refer to page 103.

NOTE: To construct a drive part number select the combination of features required and put all the coded information in the proper sequence. Please account for all entries. The model number shown is an example of a properly specified drive.

GENESIS SERIES DRIVES PRICING

Drive/ Voltage	HP	Converter Type	Enclosure	Base Model ^① Number	List Price
					\$
Model 500 230 VAC	.25-1	Non-Regenerative	Chassis	C001.5N2CH000NN	2,225
	.25-1	Regenerative	Chassis	C001.5R2CH000NN	2,695
	.25-1	Servo Regenerative	Chassis	C001.5S2CH000NN	2,895
	.25-1	Non-Regenerative	NEMA 1	C001.5N2N1000NN	2,335
	.25-1	Regenerative	NEMA 1	C001.5R2N1000NN	2,795
	.25-1	Servo Regenerative	NEMA 1	C001.5S2N1000NN	2,995
	1.5-3	Non-Regenerative	Chassis	C003.5N2CH000NN	2,225
	1.5-3	Regenerative*	Chassis	C003.5R2CH000NN	2,695
	1.5-3	Servo Regenerative*	Chassis	C003.5S2CH000NN	2,895
	1.5-3	Non-Regenerative	NEMA 1	C003.5N2N1000NN	2,335
	1.5-3	Regenerative*	NEMA 1	C003.5R2N1000NN	2,795
	1.5-3	Servo Regenerative*	NEMA 1	C003.5S2N1000NN	2,995
Model 1000 230 VAC	1	Non-Regenerative	Chassis	C0011.N2CH000NNNN	2,347
	1.5	Non-Regenerative	Chassis	C1.51.N2CH000NNNN	2,347
	2	Non-Regenerative	Chassis	C0021.N2CH000NNNN	2,347
	3	Non-Regenerative	Chassis	C0031.N2CH000NNNN	2,347
	5	Non-Regenerative	Chassis	C0051.N2CH000NNNN	3,162
	7.5	Non-Regenerative	Chassis	C7.51.N2CH000NNNN	4,017
	10	Non-Regenerative	Chassis	C0101.N2CH000NNNN	4,639
Model 1000 460 VAC	1	Non-Regenerative	Chassis	C0011.N4CH000NNNN	3,162
	1.5	Non-Regenerative	Chassis	C1.51.N4CH000NNNN	3,162
	2	Non-Regenerative	Chassis	C0021.N4CH000NNNN	3,162
	3	Non-Regenerative	Chassis	C0031.N4CH000NNNN	3,162
	5	Non-Regenerative	Chassis	C0051.N4CH000NNNN	3,563
	7.5	Non-Regenerative	Chassis	C7.51.N4CH000NNNN	3,658
	10	Non-Regenerative	Chassis	C0101.N4CH000NNNN	3,658
Model 1000A 230 VAC	1	Regenerative	Chassis	C0011AR2CH000NNNN	3,520
	1	Torque Command	Chassis	C0011AT2CH000NNNN	3,791
	1	Servo Regenerative	Chassis	C0011AS2CH000NNNN	3,900
	1.5	Regenerative	Chassis	C1.51AR2CH000NNNN	3,520
	1.5	Torque Command	Chassis	C1.51AT2CH000NNNN	3,791
	1.5	Servo Regenerative	Chassis	C1.51AS2CH000NNNN	3,900
	2	Regenerative	Chassis	C0021AR2CH000NNNN	3,520
	2	Torque Command	Chassis	C0021AT2CH000NNNN	3,791
	2	Servo Regenerative	Chassis	C0021AS2CH000NNNN	3,900
	3	Regenerative	Chassis	C0031AR2CH000NNNN	3,520
	3	Torque Command	Chassis	C0031AT2CH000NNNN	3,791
	3	Servo Regenerative	Chassis	C0031AS2CH000NNNN	3,900
	5	Regenerative	Chassis	C0051AR2CH000NNNN	4,110
	5	Torque Command	Chassis	C0051AT2CH000NNNN	4,380
	5	Servo Regenerative	Chassis	C0051AS2CH000NNNN	4,490
	7.5	Regenerative	Chassis	C7.51AR2CH000NNNN	5,221
	7.5	Torque Command	Chassis	C7.51AT2CH000NNNN	5,492
	7.5	Servo Regenerative	Chassis	C7.51AS2CH000NNNN	5,601
	10	Regenerative	Chassis	C0101AR2CH000NNNN	6,031
	10	Torque Command	Chassis	C0101AT2CH000NNNN	6,368
10	Servo Regenerative	Chassis	C0101AS2CH000NNNN	6,411	

① To construct a complete model number with available options refer to the Model Number Codes beginning on page 81.

* Externally mounted regenerative resistor

GENESIS SERIES DRIVES PRICING

Drive/ Voltage	HP	Converter Type	Enclosure	Base Model ^① Number	List Price
					\$
Model 1000A 460 VAC	1	Regenerative	Chassis	C0011AR4CH000NNNN	4,335
	1	Torque Command	Chassis	C0011AT4CH000NNNN	4,608
	1	Servo Regenerative	Chassis	C0011AS4CH000NNNN	4,715
	1.5	Regenerative	Chassis	C1.51AR4CH000NNNN	4,335
	1.5	Torque Command	Chassis	C1.51AT4CH000NNNN	4,608
	1.5	Servo Regenerative	Chassis	C1.51AS4CH000NNNN	4,715
	2	Regenerative	Chassis	C0021AR4CH000NNNN	4,335
	2	Torque Command	Chassis	C0021AT4CH000NNNN	4,608
	2	Servo Regenerative	Chassis	C0021AS4CH000NNNN	4,715
	3	Regenerative	Chassis	C0031AR4CH000NNNN	4,335
	3	Torque Command	Chassis	C0031AT4CH000NNNN	4,608
	3	Servo Regenerative	Chassis	C0031AS4CH000NNNN	4,715
	5	Regenerative	Chassis	C0051AR4CH000NNNN	4,631
	5	Torque Command	Chassis	C0051AT4CH000NNNN	4,902
	5	Servo Regenerative	Chassis	C0051AS4CH000NNNN	5,011
	7.5	Regenerative	Chassis	C7.51AR4CH000NNNN	4,755
	7.5	Torque Command	Chassis	C7.51AT4CH000NNNN	5,026
	7.5	Servo Regenerative	Chassis	C7.51AS4CH000NNNN	5,135
	10	Regenerative	Chassis	C0101AR4CH000NNNN	4,755
	10	Torque Command	Chassis	C0101AT4CH000NNNN	5,026
10	Servo Regenerative	Chassis	C0101AS4CH000NNNN	5,135	
15	Non-Regenerative	Chassis	C0151AN4CH000NNNN	4,378	
15	Regenerative	Chassis	C0151AR4CH000NNNN	5,691	
15	Torque Command	Chassis	C0151AT4CH000NNNN	5,961	
Model 2000 230 VAC	15	Non-Regenerative	Chassis	C0152.N2CH000NNNN	6,190
	15	Regenerative	Chassis	C0152.R2CH000NNNN	8,046
	15	Torque Command	Chassis	C0152.T2CH000NNNN	8,501
	20	Non-Regenerative	Chassis	C0202.N2CH000NNNN	9,122
	20	Regenerative	Chassis	C0202.R2CH000NNNN	11,858
	20	Torque Command	Chassis	C0202.T2CH000NNNN	12,305
Model 2000 460 VAC	20	Non-Regenerative	Chassis	C0202.N4CH000NNNN	5,860
	20	Regenerative	Chassis	C0202.R4CH000NNNN	7,618
	20	Torque Command	Chassis	C0202.T4CH000NNNN	7,960
	25	Non-Regenerative	Chassis	C0252.N4CH000NNNN	6,986
	25	Regenerative	Chassis	C0252.R4CH000NNNN	8,388
	25	Torque Command	Chassis	C0252.T4CH000NNNN	8,730
	30	Non-Regenerative	Chassis	C0302.N4CH000NNNN	7,346
	30	Regenerative	Chassis	C0302.R4CH000NNNN	8,748
	30	Torque Command	Chassis	C0302.T4CH000NNNN	9,090
	40	Non-Regenerative	Chassis	C0402.N4CH000NNNN	9,122
	40	Regenerative	Chassis	C0402.R4CH000NNNN	11,858
	40	Torque Command	Chassis	C0402.T4CH000NNNN	12,200

① To construct a complete model number with available options refer to the Model Number Codes beginning on page 81.

A

MOTORS

B

DRIVES

C

PRE-ENGINEERED
DRIVE SYSTEMS

D

GENERAL
INFORMATION

GENESIS SERIES DRIVES PRICING

Drive/ Voltage	HP	Converter Type	Enclosure	Base Model ^① Number	List Price
					\$
Model 3000 460 VAC	50	Non-Regenerative	Chassis	C0503.N4CH000NNNN	10,096
	50	Regenerative	Chassis	C0503.R4CH000NNNN	13,125
	50	Torque Command	Chassis	C0503.T4CH000NNNN	13,461
	60	Non-Regenerative	Chassis	C0603.N4CH000NNNN	11,956
	60	Regenerative	Chassis	C0603.R4CH000NNNN	15,542
	60	Torque Command	Chassis	C0603.T4CH000NNNN	15,878
	75	Non-Regenerative	Chassis	C0753.N4CH000NNNN	13,897
	75	Regenerative	Chassis	C0753.R4CH000NNNN	18,066
	75	Torque Command	Chassis	C0753.T4CH000NNNN	18,402
Model 3500 460 VAC	100	Non-Regenerative	Chassis	C10035N4CH000NNNN	18,722
	100	Regenerative	Chassis	C10035R4CH000NNNN	22,634
	100	Torque Command	Chassis	C10035T4CH000NNNN	22,552
Model 4000 460 VAC	125	Non-Regenerative	Chassis	C1254.N4CH000NNNN	24,422
	125	Regenerative	Chassis	C1254.R4CH000NNNN	29,525
	125	Torque Command	Chassis	C1254.T4CH000NNNN	29,418
	150	Non-Regenerative	Chassis	C1504.N4CH000NNNN	27,136
	150	Regenerative	Chassis	C1504.R4CH000NNNN	32,806
	150	Torque Command	Chassis	C1504.T4CH000NNNN	32,687

① To construct a complete model number with available options refer to the Model Number Codes beginning on page 81.

GENESIS SERIES DIMENSIONS AND WEIGHTS

A

MOTORS

B

DRIVES

C

PRE-ENGINEERED
DRIVE SYSTEMS

D

GENERAL
INFORMATION

DRIVES

Drive Model	Height		Width		Depth		Weight	
	inches	cm	inches	cm	inches	cm	lbs.	kg
500 (open chassis)	12.50	31.75	9.13	23.19	4.88	12.40	10	4.3
500 (NEMA 1)	13.00	33.02	9.13	23.19	4.88	12.40	10	4.3
1000	13.00	33.02	9.85	25.02	9.13	23.19	32	14.5
1000A	18.00	45.72	9.85	25.02	9.13	23.19	43	19.5
2000	19.50	49.53	13.75	34.93	13.38	33.99	95	43.1
3000	25.25	64.14	13.75	34.93	13.38	33.99	115	52.2
3500	28.00	71.12	24.13	61.29	14.00	35.56	207	93.9
4000	39.00	99.06	33.00	83.82	13.00	33.02	242	109.8

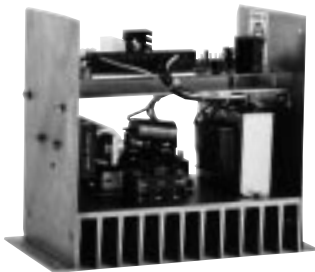

For Bus Loader diagram and pricing see page 91.

STANDARD BUS LOADERS

Model 500 and Model 1000A regenerative drives less than 10 HP @ 230 VAC and less than 15 HP @ 460 VAC have integral Bus Loaders. All other drives have separately mounted bus loaders. Standard Bus Loaders are specified for 10% duty cycle.

Motor HP	Height		Width		Depth		Weight	
	inches	cm	inches	cm	inches	cm	lbs.	kg
All	8.15	20.70	9.82	24.94	5.07	12.88	10	4.54

STANDARD RESISTOR CAGES

Standard regenerative drives require 1 resistor for each 5 horsepower, except 60 HP @ 460 VAC uses 11 and 75 HP @ 460 VAC uses 12. Standard 460 VAC drives use 70 ohm resistors rated at 375 watts. Standard 230 VAC drives use 25 ohm resistors rated at 375 watts.

Number of Resistors	Height		Width		Depth		Weight	
	inches	cm	inches	cm	inches	cm	lbs.	kg
1-4	5.81	14.76	7.13	18.11	16.36	41.55	24	10.89
5-8	5.81	14.76	11.38	28.91	16.36	41.55	38	17.24
9-12	7.75	19.69	11.38	28.91	16.36	41.55	52	23.59

NOTE: All dimensions and weights are approximate.

GENESIS SERIES TYPICAL CONNECTION DIAGRAMS

Non-Regenerative Drive Typical Connections

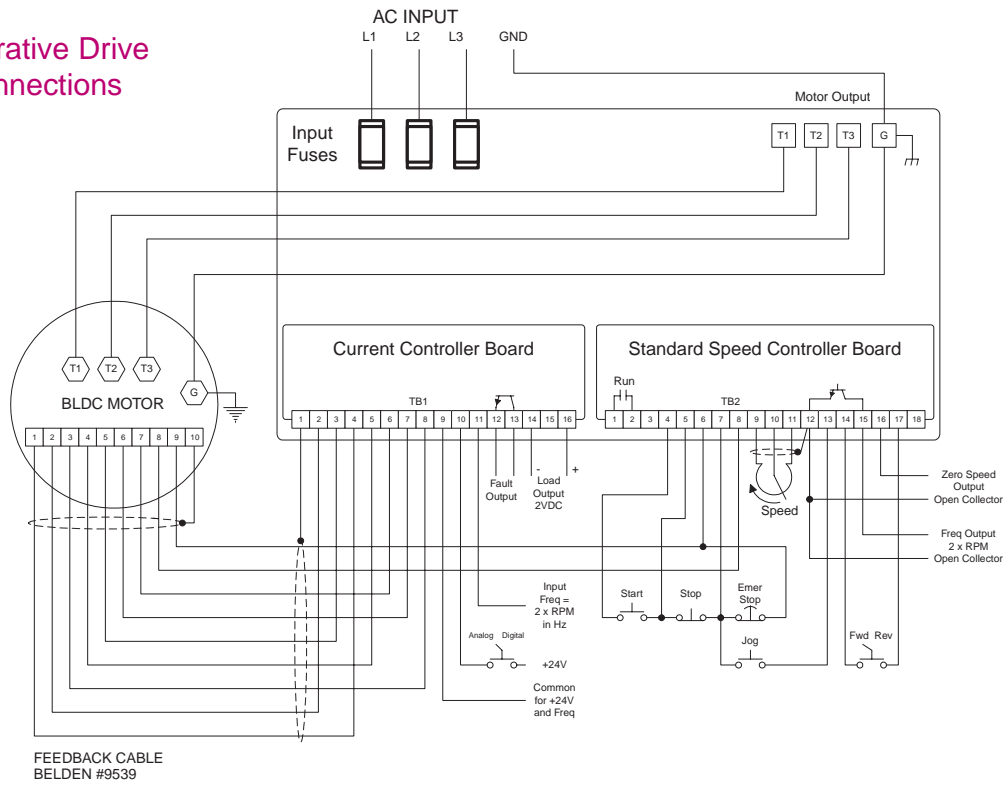

Regenerative Drive with External Bus Loader Typical Connections

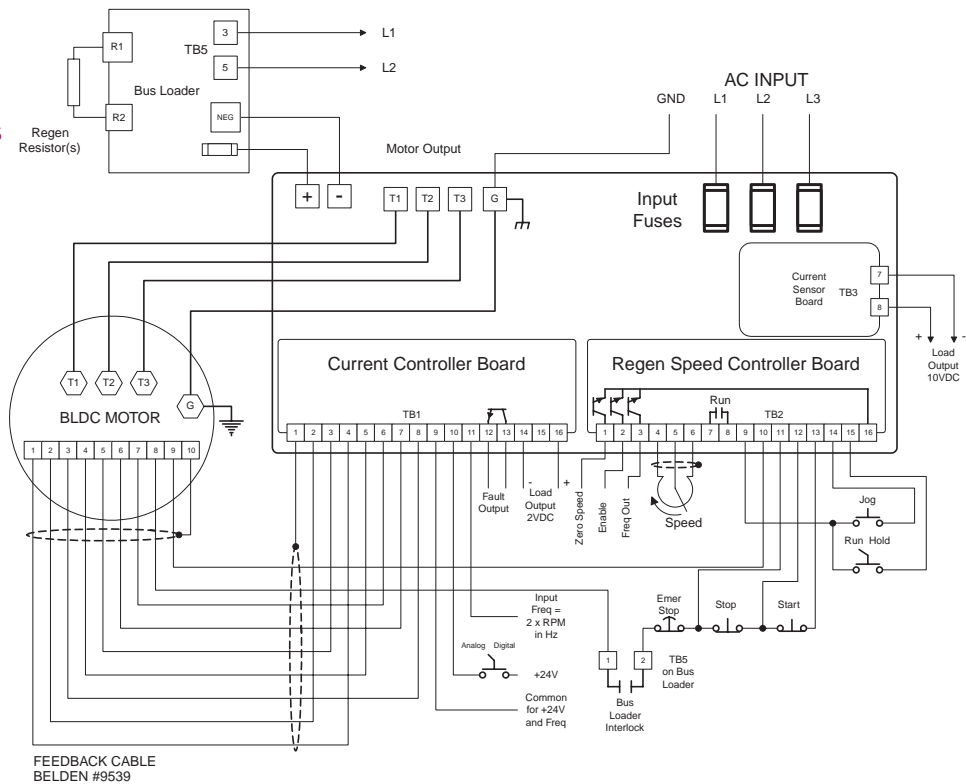

GENESIS SERIES EFFICIENCY RATINGS

Motor HP	Drive Model	Typical ^① Drive Efficiency	Typical Input kVA Per HP	AC Input Line Current amps/line
1	500	92.0	0.98	1.2
1	1000	90.5	0.99	1.2
1.5	500	92.2	0.94	1.8
2	500	92.4	0.92	2.3
2	1000	90.9	0.93	2.3
3	500	92.6	0.90	3.4
3	1000	93.9	0.88	3.4
5	1000	93.9	0.88	5.5
7.5	1000	94.9	0.86	8.1
10	1000	95.9	0.85	10.6
15	1000	96.1	0.84	15.9
20	2000	96.1	0.84	21.1
25	2000	96.2	0.84	26.4
30	2000	96.2	0.84	31.6
40	2000	96.3	0.84	42.1
50	3000	96.3	0.84	52.6
60	3000	96.4	0.84	63.0
75	3000	96.6	0.83	78.6
100	3500	96.7	0.83	104.6
125	4000	96.9	0.83	130.5
150	4000	97.1	0.83	156.2

① Efficiency ratings at motor base speed, full load operation. Actual efficiency may vary.

A

MOTORS

B

DRIVES

C

PRE-ENGINEERED
DRIVE SYSTEMS

D

GENERAL
INFORMATION

GENESIS SERIES TECHNICAL SPECIFICATIONS

A

MOTORS

B

DRIVES

C

PRE-ENGINEERED
DRIVE CYCLES

D

GENERAL
INFORMATION

DRIVE MODEL	500	1000(A)	2000	3000	3500	4000
SERVICE FACTOR	1.0	1.0	1.0	1.0	1.0	1.0
ALTITUDE	Use above 3300 feet (1000 meters) requires de-rating De-rate at 3% of full rating for each additional 1100 ft. (330 m)					
RELATIVE HUMIDITY	Less than 95%, non-condensing					
AMBIENT TEMPERATURE						
Air Surrounding Chassis Units	32 to 131°F 0 to 55°C	32 to 131°F 0 to 55°C	32 to 131°F 0 to 55°C	32 to 131°F 0 to 55°C	32 to 131°F 0 to 55°C	32 to 131°F 0 to 55°C
Air Surrounding NEMA 1 Enclosures	32 to 104°F 0 to 40°C	NA NA	NA NA	NA NA	NA NA	NA NA
INPUT VOLTAGE						
VAC (3 Phase) (±10%)	115-230 VAC [●]	230, 460 VAC	230, 460 VAC	230, 460 VAC	230, 460 VAC	230, 460 VAC
AC Frequency	50-400 Hz	48-62 Hz	48-62 Hz	48-62 Hz	48-62 Hz	48-62 Hz
DC	180-350 VDC	NA	NA	NA	NA	NA
ACCEL/DECCEL TIME	0.2-60 sec	0.2-30 sec	2-30 sec	2-30 sec	2-30 sec	2-30 sec
ADJUSTABLE CURRENT LIMIT (% rated)						
Motoring	0-150%	0-150%	0-150%	0-150%	0-150%	0-150%
Regenerative (regen drives only)	0-150%	0-150%	0-150%	0-150%	0-150%	0-150%
INPUT REFERENCE						
Analog (bipolar differential input)	0 to ±10 VDC	0 to ±10 VDC	0 to ±10 VDC	0 to ±10 VDC	0 to ±10 VDC	0 to ±10 VDC
Digital (optically isolated square wave)	0-14,000 Hz	0-14,000 Hz	0-14,000 Hz	0-14,000 Hz	0-14,000 Hz	0-14,000 Hz
ANALOG REFERENCE						
Linearity (output speed to input frequency)	±1.0%	±1.0%	±1.0%	±1.0%	±1.0%	±1.0%
Speed Regulation (constant reference)	±0.1%	±0.1%	±0.1%	±0.1%	±0.1%	±0.1%
Speed Drift (referenced to input frequency)	±0.25%	±0.25%	±0.25%	±0.25%	±0.25%	±0.25%
DIGITAL REFERENCE						
Linearity (output speed to input frequency)	0.0%	0.0%	0.0%	0.0%	0.0%	0.0%
Speed Regulation (constant reference)	0.0%	0.0%	0.0%	0.0%	0.0%	0.0%
Speed Drift (referenced to input frequency)	0.0%	0.0%	0.0%	0.0%	0.0%	0.0%
MAX LOAD (max 1 minute of 10 minutes)	150%	150%	150%	150%	150%	150%
INSTANTANEOUS TRIP (% RMS rating)	250%	300%	300%	300%	300%	300%
POWER LOSS COAST-THROUGH	100 msec	80 msec	80 msec	80 msec	80 msec	80 msec
STABILITY ADJUSTMENT (dynamic range)	20:1	20:1	20:1	20:1	20:1	20:1
GAIN ADJUSTMENT (shaft error angle)	10:1	10:1	10:1	10:1	10:1	10:1
DISPLACEMENT POWER FACTOR	0.955	>0.96	>0.96	>0.96	>0.96	>0.96

● 1 or 3 Phase

GENESIS SERIES BUS LOADERS

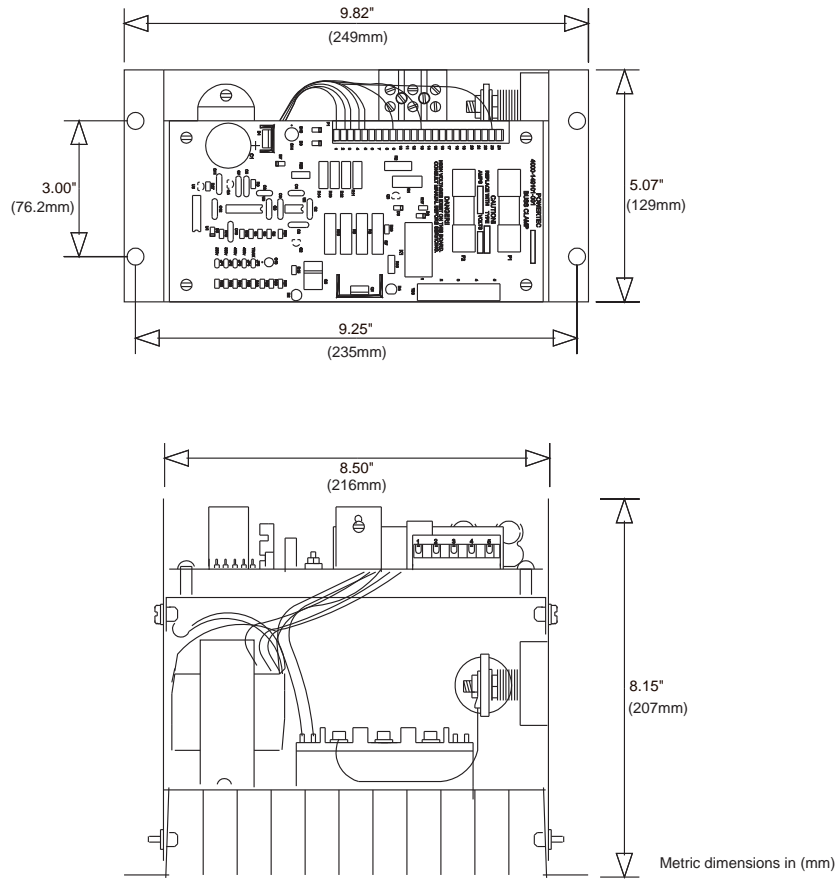

A

MOTORS

B

DRIVES

C

PRE-ENGINEERED
DRIVE SYSTEMS

D

GENERAL
INFORMATION

GENESIS SERIES BUS LOADERS

HP	Drive Model	230VAC	List Price	460VAC	List Price
			\$		\$
1/2 to 5	1000	RxxxA21000 [●]	1,304	RxxxA41000 [●]	1,267
7.5	1000	R7.5A21000	1,304	R7.5A41000	1,267
10	1000	R010A21000	1,304	R010A41000	1,267
15	2000	R015A21000	1,680	R015A41000	1,304
20	1000	NA	NA	R020A41000	1,304
20	2000	R0200A1000	1,680	NA	NA
25	2000	NA	NA	R025A41000	1,680
30	2000	NA	NA	R030A41000	1,680
40	2000	NA	NA	R040A41000	1,680
50	3000	NA	NA	R050A41000	1,715
60	3000	NA	NA	R060A41000	1,715
75	3000	NA	NA	R075A41000	1,715
100	3000	NA	NA	R100A41000	1,800

● Complete the part number by entering the HP required. 1/2 HP = 0.5, 1.5 HP = 1.5, etc.
NOTE: All Bus Loaders are rated for 10% Duty Cycle.

MILLENNIUM® SERIES BRUSHLESS DC DRIVES

The Millennium Series of high performance, brushless adjustable speed drives combines ease of set-up, an intelligent command interface, and servo-like response to meet your most demanding adjustable speed applications.

Simple software provides easy set-up to your application-specific requirements. A Digital Signal Processor controls torque, velocity and position. Millennium Series drives cover a range from 10 to 300 HP and are power-matched to our broad selection of brushless motors for optimum motor/drive configurations.

Simple Set-Up, Diagnostics

With many drives, you spend hours configuring the hardware. Millennium set-up is easy. Millennium PowerTool software includes preset application templates that eliminate the need for programming expertise. Motor Key

Codes, standard on all our brushless motors, are loaded into the drive to eliminate the need for tuning. Once the drive is enabled, on-line diagnostics monitor critical drive functions.

High Performance, Precision Control

Millennium high performance brushless drives and Pacific Scientific's motor technology provide key features for precise motion control. Millennium features digital speed control with a Constant Torque Speed Range of 1000:1, ultra-smooth low speed operation without derating, and full torque at 0 speed. Speed regulation is 0% with this synchronous drive/motor combination. A high dynamic response is achieved by matching the drive with our high torque-to-inertia brushless motors. The result is

servo-like response to speed and load changes, an important requirement for a growing number of precision motion control systems.

Low Power Consumption

Count on significant energy savings with Millennium's low power consumption. High efficiency is achieved with a pulse width modulated motor power circuit. The circuit has a near unity power factor, resulting in considerably less current draw than other drives and less heat generation.

Innovative Packaging

Millennium's modular architecture means unmatched flexibility and reduced package size. These high-powered, rugged drives are available in open-chassis or totally-enclosed chassis and may be wall mounted or inside your machine.



MILLENNIUM SERIES BRUSHLESS DC DRIVES

FEATURES	BENEFITS
Open chassis or totally enclosed chassis	Flexible packaging: chassis mount for customer designed system or totally enclosed for external mounting, eliminating the need for expensive and large cabinets
Two or four quadrant operation	Excellent control for both regenerative and non-regenerative applications
Seven programmable template settings	Software configurable user connections for simple yet versatile interface
Motor Key Codes	Configures drive to motor's specific operating parameters
5 isolated programmable logic inputs	<ul style="list-style-type: none"> - User selectable sourcing or sinking operation - Functionality determined by template setting
Pulse train input 0-255kHz: quadrature signal or step and direction	Digital speed references provide the capability of speed accuracies to 0% regulation
Analog input: 0 to ± 10 VDC differential or 4-20mA	Differential input amplifier eliminates electrical noise
<ul style="list-style-type: none"> - 2-75Hz velocity loop bandwidth - 600Hz current loop bandwidth 	High dynamic response
Three relay outputs (one programmable)	Two assigned digital outputs (READY, ENABLE) one is programmable: 125 VAC @ 0.5A or 30 VDC @ 2A
Speed and load analog outputs	0 to ± 10 VDC @ 5mA metering outputs representing motor speed and load
Torque or velocity control	Simple programming change will provide torque command or velocity command
Electronic gearing	Provides bi-directional digital and position follower modes
Automatic fault logging	Logs fault codes and time of occurrence to aid in troubleshooting
Power loss coast through	Drive will continue to operate during momentary power loss
0% speed regulation	Built in speed feedback/phase lock loop control provides precise speed control
Constant Torque Speed Range (CTSR), 1000:1	Precise speed and current regulation through the entire motor speed-torque range
Standard two year warranty	Assured quality and reliability

A

MOTORS

B

DRIVES

C

PRE-ENGINEERED
DRIVE SYSTEMS

D

GENERAL
INFORMATION

MILLENNIUM SERIES BRUSHLESS DC DRIVES



FEATURES

- Brushless servo performance
- Programmable power loss coast-through
- Seven programmable template settings
- Five isolated programmable logical inputs
- 0 to ± 10 VDC or 4–20 mA differential analog input
- Torque or velocity control
- Automatic fault logging
- Two- or four-quadrant operation
- Typical 2–75 Hz velocity loop bandwidth; 600 Hz current loop
- Pulse train input: quadrature signal or step-and-direction, 0–255 kHz (requires pulse train I/O board)
- Electronic gearing
- Three relay outputs (one programmable)
- Speed and load analog outputs
- Chassis or totally enclosed

PRODUCT DESCRIPTION

Pacific Scientific's Millennium Series Brushless DC Drives are premium performance, closed loop, software-configurable drives designed for application flexibility. Models M5, M6 and M7 employ a modular design consisting of a Bus Converter Module and a Power Bridge Module. All drives are available in open chassis or totally-enclosed designs, ideally suited for harsh industrial environments.

Motors are power matched to the Millennium Series Drives and are supplied with Motor Key Codes which eliminate the need for tuning. Drive set-up is simplified with Application Template selection using Millennium PowerTool software. This allows velocity or torque control using analog or digital references with a variety of control switch configurations.

The Millennium Series uses three microprocessors to control such functions as the programmable analog and digital inputs and outputs, inter-drive communications, and output waveform manipulation. This superior drive intelligence uses resolver feedback from the brushless motor for a digital feedback signal of 65,536 counts per revolution. This produces ultra-smooth operating speeds as low as 0.01 RPM. This servo-like response makes the Millennium Series the ideal choice for applications requiring precise speed control and high torque at very low speeds with premium efficiency.

TYPICAL APPLICATIONS

- Test stands
- Extruders
- Electronic line shafting
- Winders
- Wire drawing
- Printing
- Forest Industry machinery
- Tube and rolling mills
- Textile machinery
- Punch presses
- Paper converting

AVAILABLE OPTIONS

- Pulse Train I/O Board

MILLENNIUM SERIES BRUSHLESS DC DRIVES



MILLENNIUM M4

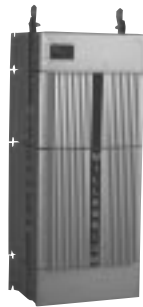
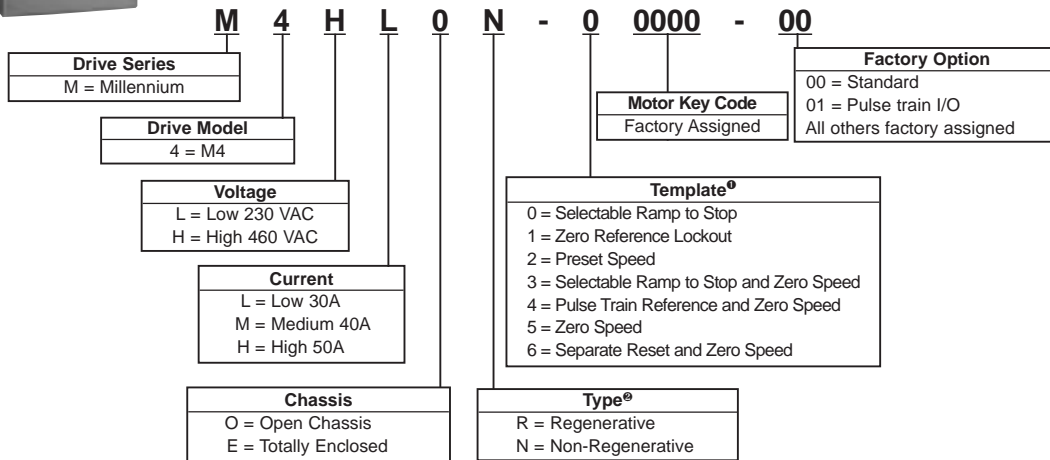

MILLENNIUM M5

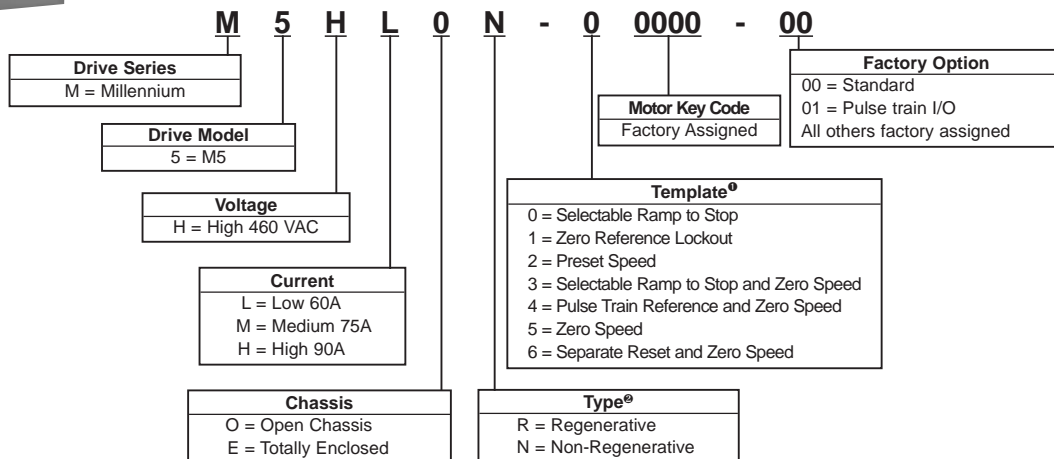

Ⓞ See MILLENNIUM Application Templates for the Standard Interface beginning on page 101.
 Ⓞ Resistor Regenerative Drives include separate Regenerative Resistor Modules. Refer to page 99 for dimensions.

A

MOTORS

B

DRIVES

C

PRE-ENGINEERED
DRIVE SYSTEMS

D

GENERAL
INFORMATION

MILLENNIUM SERIES BRUSHLESS DC DRIVES



MILLENNIUM M6

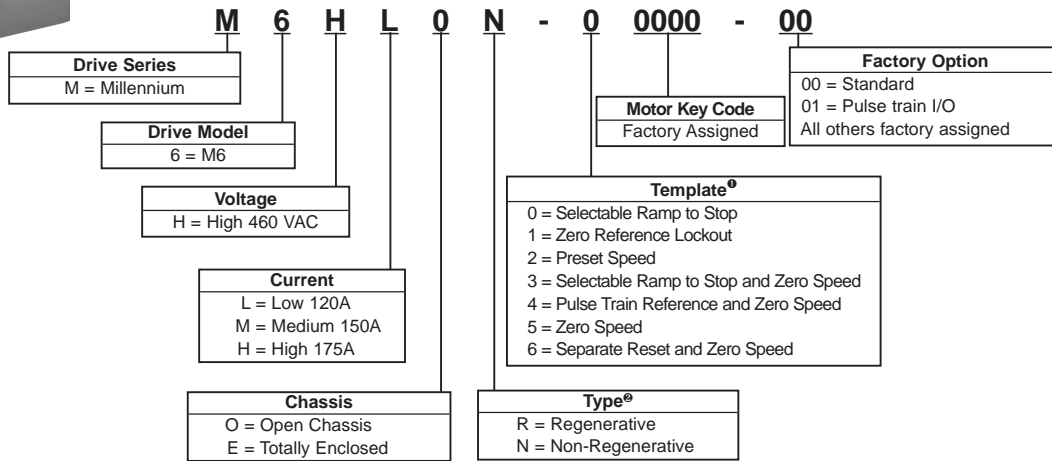

MILLENNIUM M7

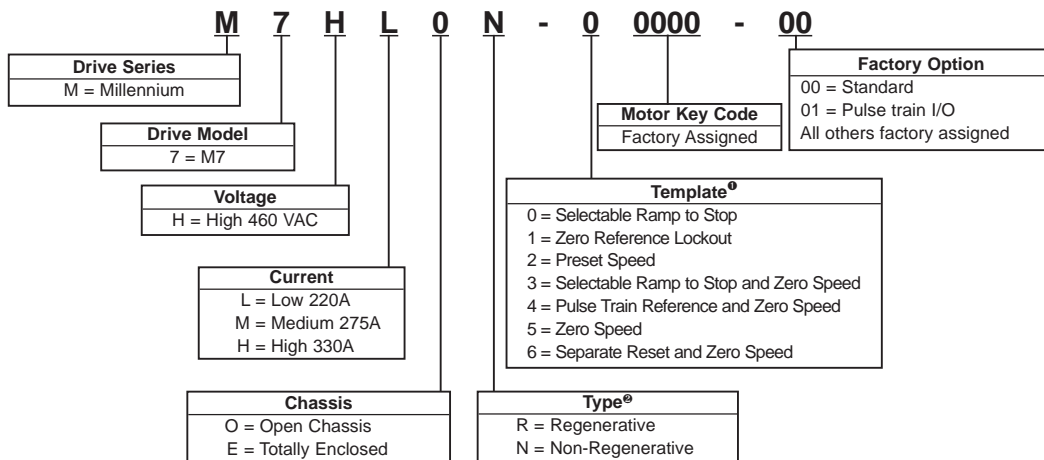

- ① See MILLENNIUM Application Templates for the Standard Interface beginning on page 101.
- ② Resistor Regenerative Drives include separate Regenerative Resistor Modules. Refer to page 99 for dimensions.

MILLENNIUM SERIES DRIVES PRICING

Drive/ Voltage	Amperes Rated/Max	Converter Type	Chassis	Base Model ^① Number	List Price
					\$
M4 230 VAC	30/45	Non-Regenerative	Open	M4LLON-XXXXX-XX	11,432
	30/45	Non-Regenerative	Totally Enclosed	M4LLEN-XXXXX-XX	13,032
	30/45	Regenerative	Open	M4LLOR-XXXXX-XX	12,084
	30/45	Regenerative	Totally Enclosed	M4LLER-XXXXX-XX	13,442
	40/60	Non-Regenerative	Open	M4LMON-XXXXX-XX	12,893
	40/60	Non-Regenerative	Totally Enclosed	M4LMEN-XXXXX-XX	14,193
	40/60	Regenerative	Open	M4LMOR-XXXXX-XX	13,632
	40/60	Regenerative	Totally Enclosed	M4LMER-XXXXX-XX	14,990
	50/75	Non-Regenerative	Open	M4LHON-XXXXX-XX	13,290
	50/75	Non-Regenerative	Totally Enclosed	M4LHEN-XXXXX-XX	14,690
	50/75	Regenerative	Open	M4LHOR-XXXXX-XX	14,011
	50/75	Regenerative	Totally Enclosed	M4LHER-XXXXX-XX	15,669
M4 460 VAC	30/45	Non-Regenerative	Open	M4HLON-XXXXX-XX	11,432
	30/45	Non-Regenerative	Totally Enclosed	M4HLEN-XXXXX-XX	13,032
	30/45	Regenerative	Open	M4HLOR-XXXXX-XX	12,084
	30/45	Regenerative	Totally Enclosed	M4HLER-XXXXX-XX	13,442
	40/60	Non-Regenerative	Open	M4HMON-XXXXX-XX	12,893
	40/60	Non-Regenerative	Totally Enclosed	M4HMEN-XXXXX-XX	14,193
	40/60	Regenerative	Open	M4HMOR-XXXXX-XX	13,632
	40/60	Regenerative	Totally Enclosed	M4HMER-XXXXX-XX	14,990
	50/75	Non-Regenerative	Open	M4HHON-XXXXX-XX	13,290
	50/75	Non-Regenerative	Totally Enclosed	M4HHEN-XXXXX-XX	14,690
	50/75	Regenerative	Open	M4HHOR-XXXXX-XX	14,011
	50/75	Regenerative	Totally Enclosed	M4HHER-XXXXX-XX	15,669
M5 460 VAC	60/90	Non-Regenerative	Open	M5HLON-XXXXX-XX	15,390
	60/90	Non-Regenerative	Totally Enclosed	M5HLEN-XXXXX-XX	16,106
	60/90	Regenerative	Open	M5HLOR-XXXXX-XX	17,114
	60/90	Regenerative	Totally Enclosed	M5HLER-XXXXX-XX	18,092
	75/113	Non-Regenerative	Open	M5HMON-XXXXX-XX	16,150
	75/113	Non-Regenerative	Totally Enclosed	M5HMEN-XXXXX-XX	17,015
	75/113	Regenerative	Open	M5HMOR-XXXXX-XX	18,023
	75/113	Regenerative	Totally Enclosed	M5HMER-XXXXX-XX	19,212
	90/135	Non-Regenerative	Open	M5HHON-XXXXX-XX	17,950
	90/135	Non-Regenerative	Totally Enclosed	M5HHEN-XXXXX-XX	18,711
	90/135	Regenerative	Open	M5HHOR-XXXXX-XX	19,903
	90/135	Regenerative	Totally Enclosed	M5HHER-XXXXX-XX	22,703

A

MOTORS

B

DRIVES

C

PRE-ENGINEERED
DRIVE SYSTEMS

D

GENERAL
INFORMATION

① To construct a complete model number with available options refer to the Model Number Codes beginning on page 95.

MILLENNIUM SERIES DRIVES PRICING

Drive/ Voltage	Amperes Rated/Max	Converter Type	Chassis	Base Model ^① Number	List Price
					\$
M6 460 VAC	120/180	Non-Regenerative	Open	M6HLON-XXXXXX-XX	23,617
	120/180	Non-Regenerative	Totally Enclosed	M6HLEN-XXXXXX-XX	25,885
	120/180	Regenerative	Open	M6HLOR-XXXXXX-XX	26,897
	120/180	Regenerative	Totally Enclosed	M6HLER-XXXXXX-XX	29,071
	150/206	Non-Regenerative	Open	M6HMON-XXXXXX-XX	26,103
	150/206	Non-Regenerative	Totally Enclosed	M6HMEN-XXXXXX-XX	26,987
	150/206	Regenerative	Open	M6HMOR-XXXXXX-XX	29,551
	150/206	Regenerative	Totally Enclosed	M6HMER-XXXXXX-XX	32,135
	175/206	Non-Regenerative	Open	M6HHON-XXXXXX-XX	27,554
	175/206	Non-Regenerative	Totally Enclosed	M6HHEN-XXXXXX-XX	29,312
	175/206	Regenerative	Open	M6HHOR-XXXXXX-XX	31,193
175/206	Regenerative	Totally Enclosed	M6HHER-XXXXXX-XX	33,920	
M7 460 VAC	220/275	Non-Regenerative	Open	M7HLON-XXXXXX-XX	45,925
	220/275	Non-Regenerative	Totally Enclosed	M7HLEN-XXXXXX-XX	47,392
	220/275	Regenerative	Open	M7HLOR-XXXXXX-XX	47,461
	220/275	Regenerative	Totally Enclosed	M7HLER-XXXXXX-XX	50,869
	275/344	Non-Regenerative	Open	M7HMON-XXXXXX-XX	48,544
	275/344	Non-Regenerative	Totally Enclosed	M7HMEN-XXXXXX-XX	52,131
	275/344	Regenerative	Open	M7HMOR-XXXXXX-XX	52,204
	275/344	Regenerative	Totally Enclosed	M7HMER-XXXXXX-XX	55,791
	330/413	Non-Regenerative	Open	M7HHON-XXXXXX-XX	51,028
	330/413	Non-Regenerative	Totally Enclosed	M7HHEN-XXXXXX-XX	54,814
	330/413	Regenerative	Open	M7HHOR-XXXXXX-XX	54,891
330/413	Regenerative	Totally Enclosed	M7HHER-XXXXXX-XX	58,677	

① To construct a complete model number with available options refer to the Model Number Codes beginning on page 95.

MILLENNIUM SERIES DIMENSIONS AND WEIGHTS

A

MOTORS

B

DRIVES

C

PRE-ENGINEERED
DRIVE SYSTEMS

D

GENERAL
INFORMATION

DRIVE

Drive Model	Height		Width		Depth		Weight	
	inches	cm	inches	cm	inches	cm	lbs.	kg
M4 (open chassis)	19.50	49.53	16.00	40.64	10.50	26.67	75	34.0
(totally enclosed)	27.00	68.58	16.00	40.64	11.75	29.85	90	40.8
M5 (open chassis)	30.50	77.47	16.00	40.64	10.50	26.67	75	34.0
(totally enclosed)	37.00	93.98	16.00	40.64	11.75	29.85	90	40.8
M6 (open chassis)	43.00	109.22	16.00	40.64	10.50	26.67	200	90.7
(totally enclosed)	57.00	144.78	16.00	40.64	11.75	29.85	240	108.9
M7 (open chassis)	50.00	127.00	29.00	73.66	10.50	26.67	395	179.2
(totally enclosed)	70.00	177.80	29.00	73.66	11.75	29.85	480	217.7

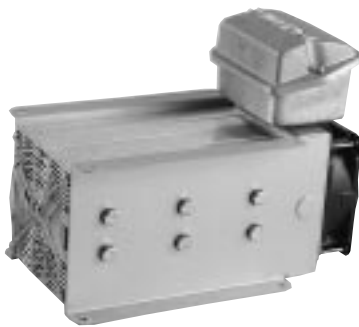

STANDARD REGENERATIVE RESISTOR MODULES

Drive Model	Motor HP	Module Number	Height ^①		Width		Depth		Weight	
			inches	cm	inches	cm	inches	cm	lbs.	kg
M4	10-40	RRM-11-12	8.75	22.23	6.63	16.83	11.88	30.16	12	5.5
M5	50-75	RRM-12-06	8.75	22.23	6.63	16.83	11.88	30.16	15	6.8
M6	100-150	RRM-24-03	8.75	22.23	11.38	28.89	11.88	30.16	25	11.4
M7	200	RRM-36-02	8.75	22.23	16.13	40.96	11.88	30.16	34	15.5
M7	250-300	RRM-48-01	8.75	22.23	21.63	54.94	11.88	30.16	45	20.5

① Includes height of 3.25" (8.26 cm) terminal box.
NOTE: All dimensions and weights are approximate.

MILLENNIUM SERIES TYPICAL CONNECTION DIAGRAMS

MILLENNIUM M4 DRIVE WITH STANDARD INTERFACE

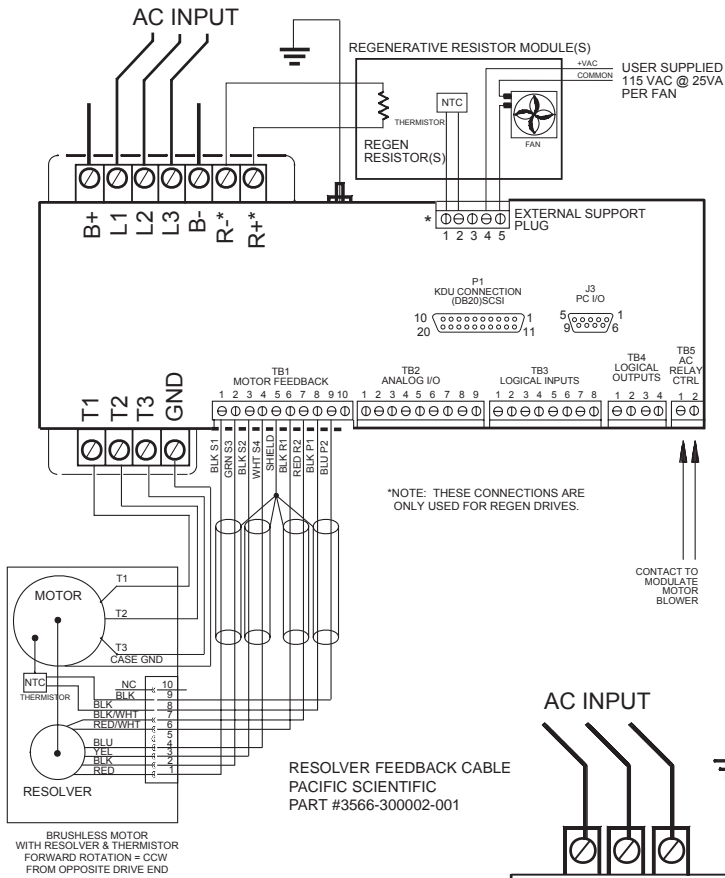

MILLENNIUM M5/M6/M7 DRIVE WITH STANDARD INTERFACE

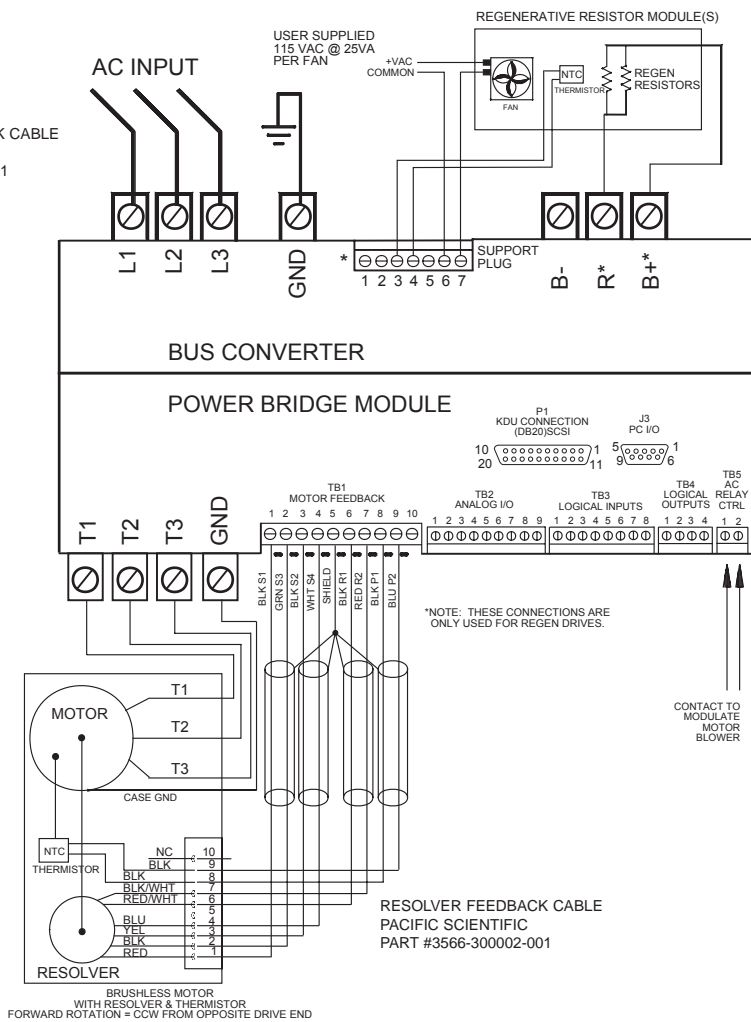

MILLENNIUM SERIES TEMPLATES AND EFFICIENCY RATINGS

A

MOTORS

APPLICATION TEMPLATES FOR THE STANDARD INTERFACE

Configuration Template		Digital Input Terminals on TB3 ^①				Digital Outputs on TB4		
No.	Motor Control Mode	3	4	5	6	1	2	3
0	Analog Speed Reference with Selectable Ramp Stop and Reverse	Start	Stop	Ramp Select	Reverse	Ready	Run	Full Load
1	Analog Speed Reference with Zero Speed Interlock and Reverse	Start	Stop		Reverse	Ready	Run	Full Load
2	Selectable Motor Operating Mode with Preset and Reverse	Start	Stop	Preset	Reverse	Ready	Run	Full Load
3	Analog Speed Reference with Selectable Ramp Stop and Zero Speed Interlock	Start	Stop	Ramp Select	Reverse	Ready	Run	Zero Speed
4	Digital Speed Reference with Pulse Train Input and Zero Speed Interlock	Start	Stop			Ready	Run	Zero Speed
5	Analog Torque Reference with Zero Speed Interlock	Start	Stop		Reverse	Ready	Run	Zero Speed
6	Analog Speed Reference with Reset and Two Wire Start/Stop Control	Run ^②	Reverse	Reset		Ready	Run	Zero Speed

① TB3 Terminal 2 is ENABLE, which cannot be changed

② Two-wire start/stop operation

B

DRIVES

EFFICIENCY RATINGS

Drive Model	Input Line Voltage VAC	Rated Current Output Amps	Peak Current Output Amps	Nominal ^① Motor HP	Typical ^② Drive Efficiency
M4	230	30	45	10	95.5
M4	230	40	60	15	95.8
M4	230	50	75	20	96.0
M4	460	30	40	25	97.5
M4	460	40	60	30	97.7
M4	460	50	75	40	97.8
M5	460	60	90	50	98.0
M5	460	75	113	60	98.0
M5	460	90	135	75	98.1
M6	460	120	180	100	98.0
M6	460	150	206	125	98.1
M6	460	165	206	150	98.1
M7	460	220	275	200	98.1
M7	460	275	344	250	98.2
M7	460	330	413	300	98.2

① Actual HP usage will be determined by motor full load current.

② Efficiency is calculated with non-regenerative drive at continuous current rating at motor base speed.

C

PRE-ENGINEERED
DRIVE SYSTEMS

D

GENERAL
INFORMATION

MILLENNIUM SERIES TECHNICAL SPECIFICATIONS

A

MOTORS

B

DRIVES

C

PRE-ENGINEERED
DRIVE CYCLES

D

GENERAL
INFORMATION

DRIVE MODEL	M4	M5	M6	M7
SERVICE FACTOR	1.0	1.0	1.0	1.0
ALTITUDE	Use above 3300 feet (1000 meters) requires de-rating De-rate at 3% of full rating for each additional 1100 ft. (330 m)			
RELATIVE HUMIDITY	Less than 95%, non-condensing			
AMBIENT TEMPERATURE				
Air Surrounding Open Chassis	41 to 122°F 5 to 50°C	41 to 122°F 5 to 50°C	41 to 122°F 5 to 50°C	41 to 122°F 5 to 50°C
Air Surrounding Totally Enclosed Chassis	41 to 104°F 5 to 40°C	41 to 104°F 5 to 40°C	41 to 104°F 5 to 40°C	41 to 104°F 5 to 40°C
INPUT VOLTAGE				
Low Voltage Units				
AC (3 Phase)	190-255 VAC	NA	NA	NA
AC Frequency	47-63 Hz	NA	NA	NA
High Voltage Units				
AC (3 Phase)	340-505 VAC	340-505 VAC	340-505 VAC	340-505 VAC
AC Frequency	47-63 Hz	47-63 Hz	47-63 Hz	47-63 Hz
DC BUS VOLTAGE				
Low Voltage Units				
DC	270-350 VDC	NA	NA	NA
High Voltage Units				
DC	460-720 VDC	460-720 VDC	460-720 VDC	460-720 VDC
INPUT REFERENCE				
Analog (differential)	0 to ±10 VDC	0 to ±10 VDC	0 to ±10 VDC	0 to ±10 VDC
Analog	4-20 mA	4-20 mA	4-20 mA	4-20 mA
Digital (quadrature or step and direction)❶	0-255 kHz	0-255 kHz	0-255 kHz	0-255 kHz
MAX LOAD (max 1 minute of 10 minutes)	150%	150%	125%	125%
POWER FACTOR (at full load)	>0.95	>0.95	>0.95	>0.95
RESOLVER (Transmitter type)				
Excitation Frequency	6.51 kHz	6.51 kHz	6.51 kHz	6.51 kHz
Output Ratio	0.5:1	0.5:1	0.5:1	0.5:1
RESOLVER FEEDBACK CABLE (Pacific Scientific Part #3566-300002-001)				
Capacitance	12.5 pF/ft.	12.5 pF/ft.	12.5 pF/ft.	12.5 pF/ft.
Impedance	100Ω	100Ω	100Ω	100Ω
Maximum Length	50 m (150 ft.)	50 m (150 ft.)	50 m (150 ft.)	50 m (150 ft.)

❶ Requires Pulse Train I/O Board

BRUSHLESS DC DRIVES OPTIONS AND PRICING

DRIVE OPTION BOARDS

Drive Option Boards are specified for retrofit or replacement purposes. Boards do not include accessory hardware or cables.

Option Board	Description	Part Number	Applicable Drive Model	List Price \$
Analog Interface Board	For accurate analog speed and load outputs. Speed output signal is 0 to ± 10 VDC for 0 to 100% speed. Load output signal is 0 to +10 VDC for 0 to 150% of load (this 0 to 10VDC is standard in the 2000, 3000, 3500, & 4000 Series). This option may also be used to provide a bipolar current analog signal for an analog meter for indicating regeneration on regenerative drives.	4001-154007-009	500	385
		4001-154007-002	1000-4000	385
Auxiliary Feedback Board	Used when the application requires feedback from a lay on roll or remote tach for operation. Most line speed winders (unless they are surface driven types) require that the feedback devices be driven independently of the motor shaft. This option provides for external summing of the normal analog reference with an analog tach feedback from a tach or other voltage source from 10VDC max. to 200VDC max. A PID loop is included on the board. Mounts onto snaptrack.	4001-148200-000	1000-4000	660
Dancer Interface Board	This option board plugs onto the 500 top board. It allows either full dancer or line speed following with dancer trim. Full PID loop control. No power supply is needed.	4001-154060-002	500	529
DC Relay Module	This is a relay mounted on a PC board which has a 110VDC relay mounted together with rectifier bridge and capacitor. It is meant to operate as a 115VAC relay replacement. The components will provide a relay hold of 100 milliseconds minimum after loss of AC power. This is necessary in systems when the drive is trying to ride through power dips. If run contacts to the drive are lost due to the power dip, the drive will stop even though the drive itself is capable of riding through.	4001-148210-001	1000-4000, M4-M7	357
Dual Ramp Accel/Decel Board	Used when the application requires more than one ramp rate for either accel or decel. The board is track-mounted and allows the setting and control of accel rate in one direction of rotation and a different rate of accel in the other direction of rotation. Decel can also be set in either direction.	4001-148204-000	1000-4000	417

A

MOTORS

B

DRIVES

C

PRE-ENGINEERED
DRIVE SYSTEMS

D

GENERAL
INFORMATION

BRUSHLESS DC DRIVES OPTIONS AND PRICING

DRIVE OPTION BOARDS (Continued)

Option Board	Description	Part Number	Applicable Drive Model	List Price \$
Logic Extender Board	Used for Dynamic Braking. Jog clockwise, Jog counterclockwise, M-Contactor, Ramp to hold and hold functions. Includes outputs for zero speed, drive running, and fault output.	4001-1540080001	500	266
Multiple Preset Speed Board⁹	(Analog Signal Switch). Up to five preset speeds can be selected by dry contacts from a remote location. Slide track mounted.	4001-148600-001	1000-4000	601
Overspeed Board	Used primarily for high speed applications but can be used anywhere that a limit on overspeed is required which is independent of other functions.	4001-152500-000	1000-4000	545
PID Board⁹	Slide track mounted board that provides for line speed operation with dancer trim or full dancer control or load cell control. Previously called Dancer Control and 3 Mode Amplifier. Provides for proportional integral and derivative adjustments for the dance input.	4001-127109-001	1000-4000	920
Power Supply Board	Slide track mounted board that accepts 115VAC or 230VAC (must be specified at the time of order) and provides +24VDC, -24VDC, common outputs and also has card edge connects to mate with option boards. This will handle up to 2 option boards.	4001-127101-001	1000-4000, M4-M7	365
Process Interface Board	Provides several interface options. It provides two different 0 to 10VDC input channels each with 4-20 mA outputs with zero and span. It provides one 4-20 mA input with 0 to 10VDC output with zero and span. These inputs are differentially isolated to 20 volts. It provides one frequency input with 0 to 10VDC output, optically isolated.	4001148230-000	1000-4000	929
Signal Processor Board⁹	Slide track mounted board to provide inputs from 4-20 mA or from voltage sources from 2VDC to 200VDC full scale. Provides for zero and span adjustments on 4-20 mA input.	4001-148300-000	1000-4000	620
System Interface Board	This board includes all the functions of the Analog Interface Board with the addition of torque control, 4-20 mA input and follower speed control functions.	4001-154036-xxx	500	537
Threshold Detector Board	Slide track mounted board that will sense two voltage "levels" or one "window" on two independent channels. Two output relays with form C-contacts powered by 115VAC.	4001-148400-000	1000-4000	585
Torque Controller Board	This board is an addition to the standard speed control board when it is necessary to control the torque limit externally. The torque control board is an extension of the current limit pot. Board is powered from the drive through ribbon cables.	4001-148101-000	1000-4000	1,210
Pulse Train I/O Board	This board is used to provide resolver/encoder input and output to and from Millennium Drives. It can be used for speed frequency following (velocity command), torque referencing (torque command), or position referencing (electronic gearing).	4001-200513-001	M4-M7	100

⁹ Requires the use of the Power Supply Board

BRUSHLESS DC DRIVES OPTIONS AND PRICING

A

MOTORS

B

DRIVES

C

PRE-ENGINEERED
DRIVE SYSTEMS

D

GENERAL
INFORMATION

DRIVE OPTION KITS

All Drive Option Kits include option board, required connector cables, and mounting hardware. Refer to Drive Option Boards for product descriptions.

Description	Part Number	Applicable Drive Model	List Price
			\$
Analog Interface	GKAIB-1000	1000-4000	415
Auxiliary Feedback	GKAIB	1000-4000	675
Dual Ramp Accel/Decel	GKDRADB	1000-4000	428
Multiple Preset Speed Board ^①	GKMPSB	1000-4000	616
Overspeed Board	GKOSB	1000-4000	580
PID Board	GKPIDB	1000-4000	950
Power Supply Board	GKPSB	1000-4000, M4-M7	380
Process Interface	GKPIB	1000-4000	944
Signal Processor ^①	GKSPB	1000-4000	635
Threshold Detector	GKTDB	1000-4000	600
Torque Control	GKTCB	1000-4000	1,250
Pulse Train I/O	GKPTIO	M4-M7	150

DRIVE ACCESSORIES

Accessory	Description	Part Number	Applicable Drive Model	List Price \$
DigiMax[®]	Keypad and display for use as a digital reference (set-point) command. Accepts a variety of digital and analog inputs and allows electronic gearing with settable gear ratio. Provides a selection of local/remote and master/slave operating modes. Includes RS-422 interface for remote communication with PLCs or host computers.	8003-153215-000	All Drives	2,150
BCDMax	Accepts BCD input for digital reference (set-point) command. Speed and ratios (master or slave) are set by a 20 line, 5 decade BCD input from either thumbwheels or PLC outputs.	4001-153400-003	1000-4000	1,803
DigiTrak[®]	Provides digital display of both motor speed in RPMs, and percentage of motor load. Speed is settable in Engineering units.	8003-153108-000	All Drives	574

① Requires the use of the Power Supply Board

② Units available for 115 VAC or 230 VAC input power. Units will be supplied for 115 VAC if not specified.

BRUSHLESS DC DRIVES DYNAMIC BRAKING KITS

Genesis and Millennium Series Drives may use passive dynamic braking to stop the motor and load. Dynamic braking is very effective on Brushless DC Motors even is power to the drive is absent because the permanent magnets on the rotor supply the necessary field flux without external power. The necessity to quickly stop a machine during a power failure, or operator safety issues, are generally examples of the need for this type of DB.

The dynamic braking contactor pulls in on any start. It does not drop out until a Drive Disable is initiated.

HP	Part Number				List Price
					\$
1-10	DB	X ^o	—	(Entire Motor Model Number)	1,068
15-40	DB	X ^o	—	(Entire Motor Model Number)	1,865
50-75	DB	X ^o	—	(Entire Motor Model Number)	2,420
100-200	DB	X ^o	—	(Entire Motor Model Number)	4,848
200-300	DB	X ^o	—	(Entire Motor Model Number)	8,080

● G = Genesis Drive
M = Millennium Drive

NOTE: Standard dynamic braking is specified for load inertia equal to or less than the motor's rotor inertia. For special circumstances, such as high inertia loads, contact the factory. Additional resistors will be additional cost items.

Resistors and Output Contactor are included in Standard Dynamic Braking Kits

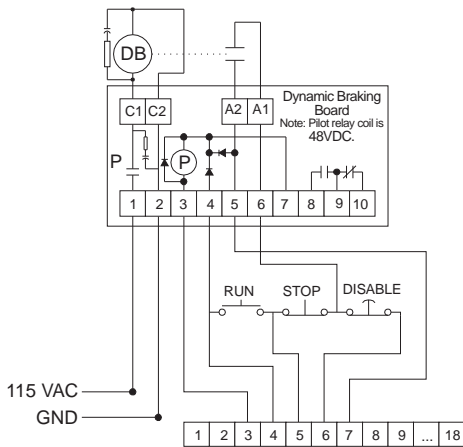

**Connection to GENESIS Drive
Terminal TB2**

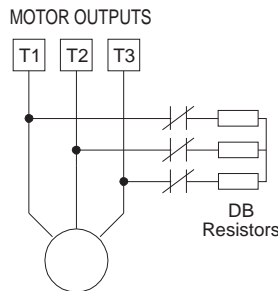

- The DB contactor requires 3 normally closed power contacts and at least one normally open auxiliary.
- The use of a 115 VAC coil on the DB contactor is strongly recommended.
- The use of a surge suppressor across the coil of the DB contactor is REQUIRED.

**Connection to MILLENNIUM Drive
Terminal TB3**

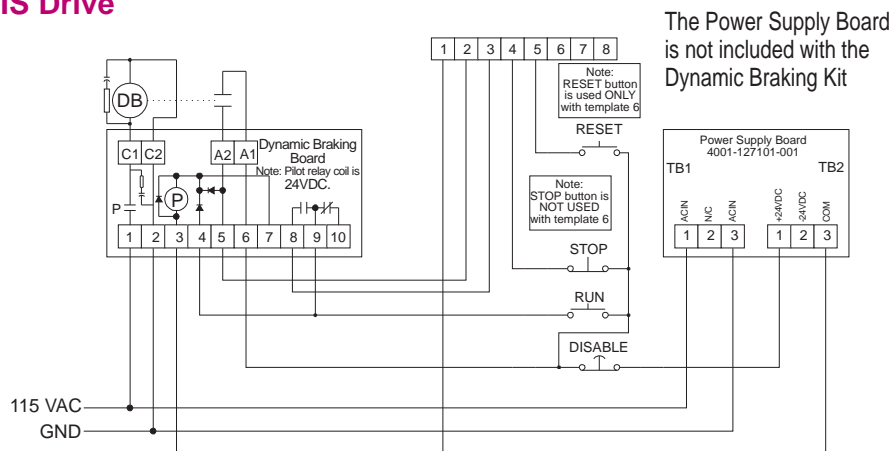

The Power Supply Board is not included with the Dynamic Braking Kit