

POWERTEC **INDUSTRIAL MOTORS**



Brushless Motor Manual

Ferrite “F” Series Motors Installation and Operation Manual

Powertec Industrial Motors
13509 South Point Blvd
Suite 190
Charlotte, NC 28273
www.powertecmotors.com

sales@powertecmotors.com

**WARNING!!! IF YOU DO NOT INSTALL AND SERVICE THIS EQUIPMENT CORRECTLY,
YOU OR SOMEONE ELSE COULD GET HURT.**

APPLICATION CHECKLIST

1. UPON RECEIPT



Our Quality Control Department inspects the motors and packing before shipment. When you receive it, inspect your order. Look for any mechanical damage that may have occurred during shipment. Report any damage you find to the freight carrier **FIRST**. Then call **POWERTEC** for help in assessing the damage.

2. STORAGE

You should store a motor in its original packaging. Keep it in a clean, dry location, protected from extremes in temperature and humidity. Rotate the shaft of a stored motor monthly. The grease may settle in the bearings and harden over time. Do not remove the cosmoline rust prevention coating from the shaft extensions until installation.

3. HANDLING

Use care in handling the motor. Avoid dropping it. Prevent sudden impacts, especially on the shaft. The lifting lugs are designed to lift the weight of the motor **ONLY**. **DO NOT** use the lifting lugs of the motor as the sole means to lift other devices, such as gearboxes, attached to the motor.

4. ENVIRONMENT

The motor ratings are for an altitude of less than 3300 feet (1000 meters). You must derate the motor for higher altitudes.

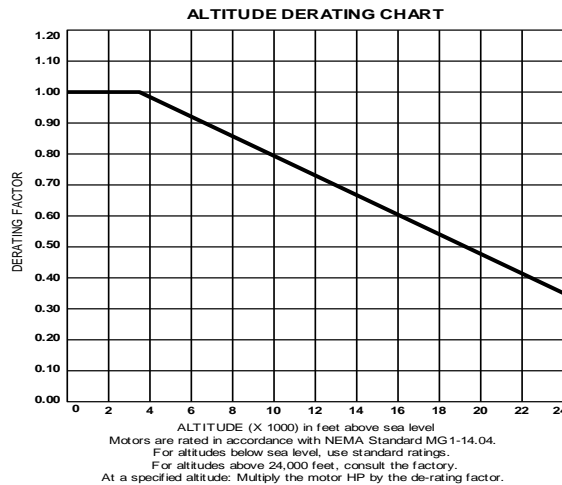

Install the motor in a clean, dry, well-ventilated area away from heat sources. Air temperature should not exceed 40 °C (104° Fahrenheit). For higher ambient temperatures, you must derate the motor. See the graph below.

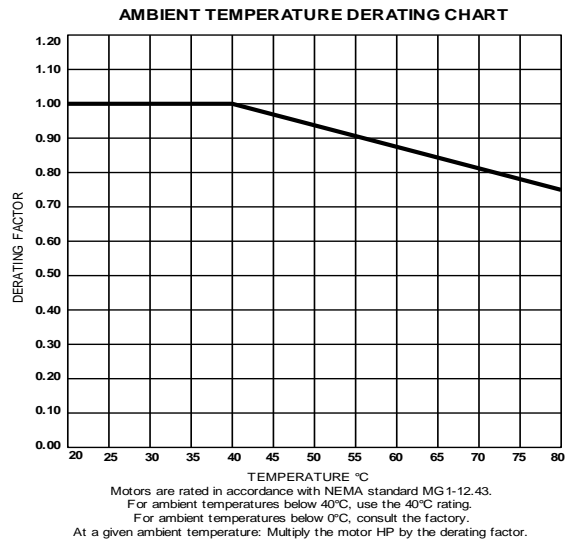

**De-rating is cumulative.
First de-rate for altitude; then de-rate for temperature.**

5. GENERAL MECHANICAL INSPECTION

Before you install the motor, verify that the motor shaft is free to turn and all mechanical parts are in their proper position. Turn the motor shaft by hand to check for damage to the rotor. Remove the Cosmoline coating on the shafts with a suitable solvent, before installation.

NOTE: If you have power leads shorted together in the junction box, the motor shaft will not turn.

6. MOUNTING

You can mount the motor in any shaft position as long as you keep radial and thrust loads within limits. Install foot-mounted motors on a rigid foundation. You must use shims if the motor mounting base is uneven. Do not cause unnecessary stress on feet, frame and bearings by using poor mounting practices.

After installation, make sure that all bolts that hold the motor in place are tight. See Mounting Bolt Torques on page 14.

7. ALIGNMENT

If the motor is directly coupled to the load, alignment is very important. The type of coupling device determines alignment tolerances. Poor alignment allows vibration, resulting in damage to the coupling, bearings, rotor, or accessory devices.

8. BELTED APPLICATIONS

It is important that you use the correct sheave size and type. You must select the proper belts. See the Maximum Shaft Radial Loading Table on page 14. When you size the sheaves wrong or tension the belts improperly, premature bearing or shaft failure may occur. Mount the sheave as close as you can to the motor housing. If you need help on sheave sizing, call **POWERTEC**.

WHEN REMOVING PULLEYS FROM THE MOTOR SHAFT, USE A PROPER PULLER. DO NOT PRY PULLEYS OFF BY LEVERAGE AGAINST THE FRAME. YOU MAY DAMAGE THE BEARINGS OR THE RETAINER PLATES BY PLACING STRESS ON THE MOTOR SHAFT RELATIVE TO THE FRAME.

9. OPERATION

After you complete the mounting and alignment steps, you may make electrical connections. You must follow the connection diagrams exactly or the motor will not operate.

If turning the wrong way will damage the equipment, verify motor direction before connecting the load. Monitor motor current during the first operation of the motor. Compare it to the motor nameplate value.

Check the motor cooling right after the start-up. Check it at fifteen-minute intervals until the motor gets to normal temperature (about four hours at full load).

10. MAINTENANCE

Make the first inspection within a few hours after placing the motor in service, to catch problems caused by the installation. Check the motor at least once per month after start-up.

Preventive maintenance means checking the motor often. Make frequent checks for excess vibration, loose mounting bolts and belts, odd noises (a steady hum is normal), and high heat output.

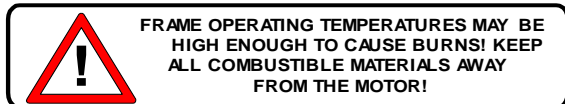

SUMMARY OF WARRANTY

Brushless DC motors built by **POWERTEC** Industrial Motors, Inc. are warranted against defects in materials and workmanship for a period of two years from the date of shipment from the factory. If a motor fails for any of these reasons during this period of time, we will repair the motor or, at our option, replace the motor. We reserve the right to determine who will make repairs, and where the repairs will be made. Claims for repairs under warranty must be submitted within 30 calendar days from the first indication of the defect. Unauthorized repairs are not covered by the warranty.

WARRANTY PROCEDURE

1. When a problem with the motor is confirmed, write down the serial number, model number, and job number of the motor. This information is listed on the nameplate.
2. Call your distributor, or our Service Department at (803) 328-1888 or FAX the information to (803) 328-1870.
3. Our service personnel will attempt to resolve the problem over the phone. They may ask for information on the machine, environment, and operation.
4. If the problem cannot be resolved over the phone, we will determine the best course of action to resolve the problem. This may consist of sending parts, or returning the motor for repairs.
5. If parts are to be sent, a purchase order will be required. A Merchandise Return Authorization (MRA) number will be issued for the parts. If the service is covered by warranty, credit for the parts will be issued upon inspection of the old parts at the factory.
6. Before the motor is returned to the factory for repair, an MRA number must be issued by the service department.
7. The MRA number must be displayed on the packaging of the motor and on all paperwork. The paperwork must include a description of the problem and return shipping instructions. Motors returned without an MRA will not be acknowledged, and we are not responsible for them.
8. On repairs covered by warranty, there will be no charges for materials and labor at the factory. The repaired or replacement motor will be sent freight collect to the user.
9. Repairs and replacements will be made in a timely manner. If the user requires expedited service, there will be a charge for the expedited service.

The warranty does not cover failures due to misapplication, improper installation, accidental or intentional abuse, incorrect electrical connections, and damages due to transportation or handling. The warranty does not apply if any unauthorized alteration has been done to the motor.

POWERTEC is not responsible for removal or re-installation costs, shipping charges, nor consequential costs or losses. There is no other warranty, expressed or implied, including fitness for the purpose intended. The maximum liability of **POWERTEC** shall be limited to the purchase price of the motor.

Quick Reference - - Model Numbering System - - Ferrite Motors

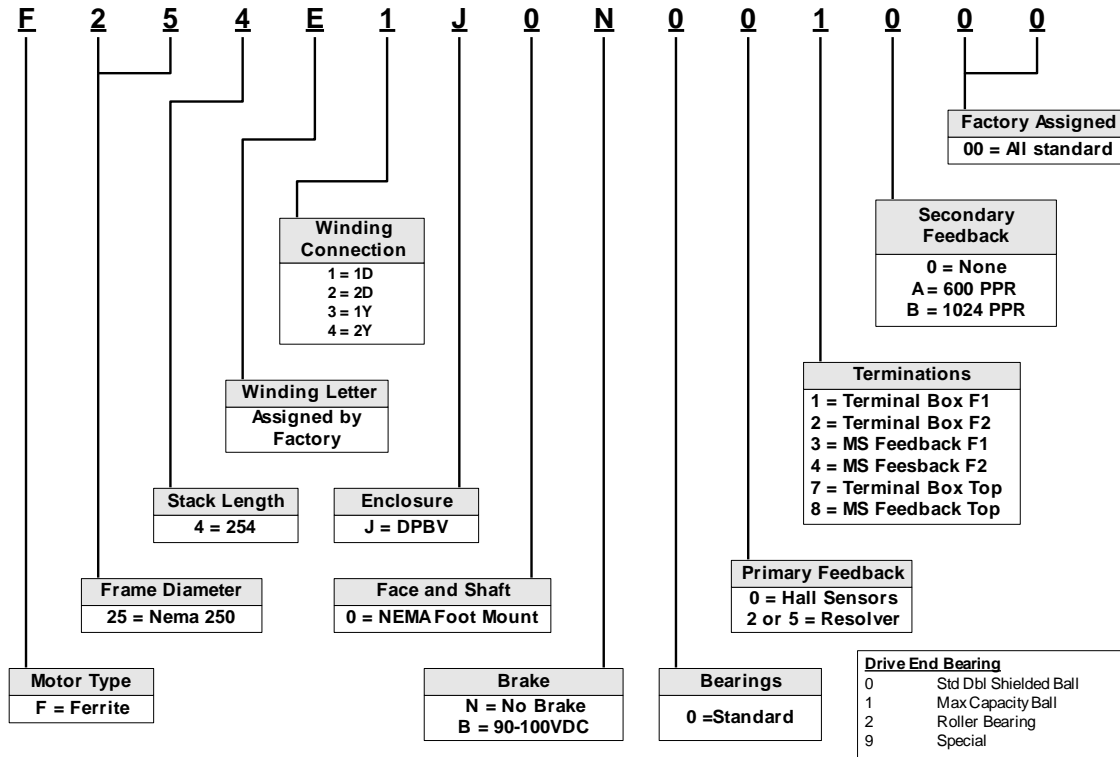

Frame Diameter	NEMA Frame	Stack Length
42	A42	A
	B42	B
	C42	C
14	143	3
	145	5
	L145	7
18	182	2
	184	4
21	213	3
	215	5
	218	8
	219	9
25	254	4
	256	6
	259	9
	2512	C
28	287	7
	288	8
	2810	A
	2812	C
32	328	8
	3211	B
	3213	D
50	502	2
	504	4
	506	6
	508	8

Enclosures

A	TENV (IP44)
B	TENV (IP56)
C	TEFC
D	TEAO
E	TEPV
F	DPFG
G	DPSV
H	DPBV (w/o filter)
J	DPBV (w/ filter)
K	SPFG
L	TENV (washdown)
M	TEXP (MSHA)
W	TEWC
X	TEXP (UL)
Z	SPECIAL

Primary Feedback

0	Hall Switch / Thermal Switch
1	Tachsyn
2	Small Bore Resolver (std) / NTC's
3	Optical Encoder
5	Large Bore Resolver (dbl shaft) / NTC's
6	No feedback
7	Resolver (special) / Thermal Switches
9	Special

Secondary Feedback

0	None
A	600 PPR Optical Encoder
B	1024 PPR Optical Encoder
M	Encoder Kit w/o encoder
N	Resolver, secondary
L	Special Encoder
9	Special Feedback

Face and Shaft

0	Std Bracket and Shaft w/feet
1	NEMA "C" face w/ feet
2	NEMA "D" flange w/ feet
3	NEMA "P" base flange
4	IEC (metric) square flange w/ feet
5	IEC (metric) round flange w/ feet
6	NEMA "C" face w/o feet
7	NEMA "D" flange w/o feet
8	IEC (metric) round flange w/o feet
9	Special
A	IEC (metric) square flange w/o feet

- | | |
|---|---------------------------------|
| 1. Key | 19. Stamped Rear Cover |
| 2. Rotor Assembly | 20. Hex Head Tapping Screw |
| 3. Bearing Retainer (End Cap) | 21. Lifting Lug |
| 4. Bearing | 22. Drive End Bracket |
| 5. Cover Gasket | 23. Wave Washer |
| 6. Cover | 24. Air Baffle |
| 7. Hex Head Screw | 25. Frame/Wound Stator Assembly |
| 8. Grease Fitting | 26. Hex Washer Head Screw |
| 9. ----- | 27. Base (Foot mount) |
| 10. Flat Washer | 28. Terminal Box Gasket |
| 11. Hex Head Screw | 29. Terminal Box |
| 12. Grease Fitting | 30. Hex Washer Head Screw |
| 13. Socket Head Screw | 31. Cable Termination Strip |
| 14. Feedback End Bracket | 32. Hex Washer Head Screw |
| 15. Feedback Stator Assembly (Resolver Shown) | 33. Terminal Strip |
| 16. Set Screw | 34. Terminal Box Cover Gasket |
| 17. Feedback Rotor Assembly (Resolver Shown) | 35. Terminal Box Cover |
| 18. Hex Washer Head Tapping Screw | 36. Hex Head Tapping Screw |

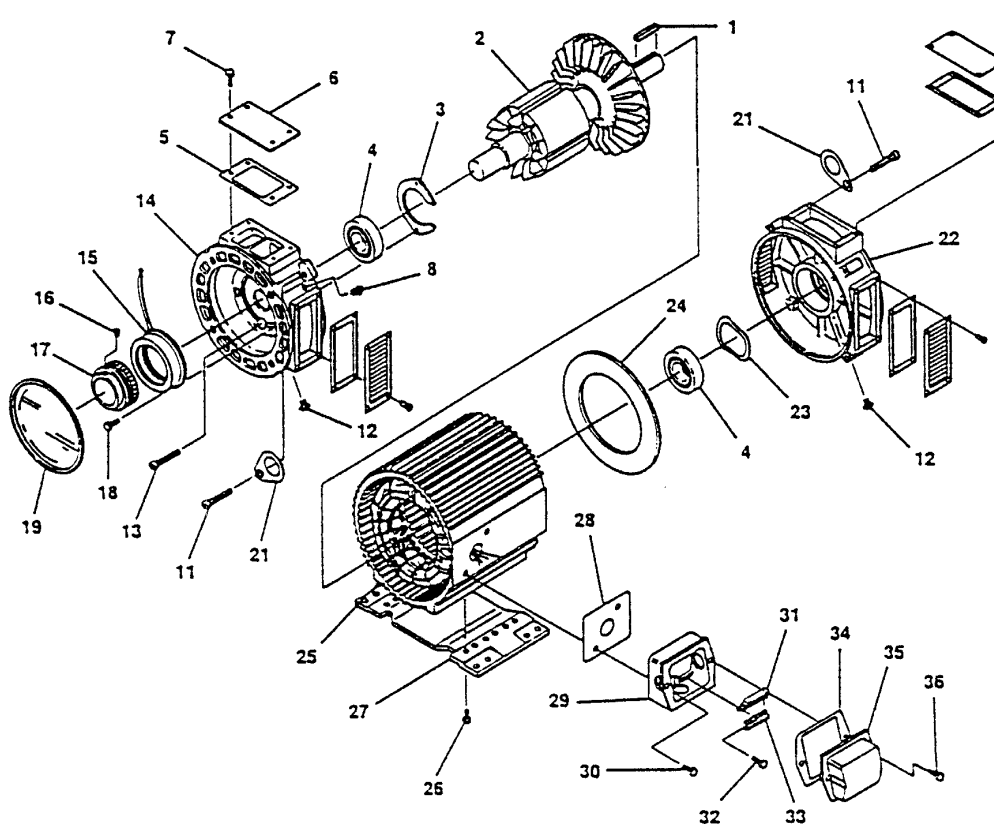

**"F" SERIES BRUSHLESS DC MOTOR
EXPLODED VIEW AND PARTS LIST**

ELECTRICAL CONNECTIONS

All connections for the motor are in the main terminal box, except on 320 frame and 500 frames. On these frames, the feedback connections are in a separate conduit box.

POWER LEADS

The motor ships from the factory already connected for the speed, voltage, and power listed on the nameplate. The correct connection of the motor is shown on the nameplate as "CONNECTION _D _Y". There will be a number "1" or "2" in front of one of these symbols.

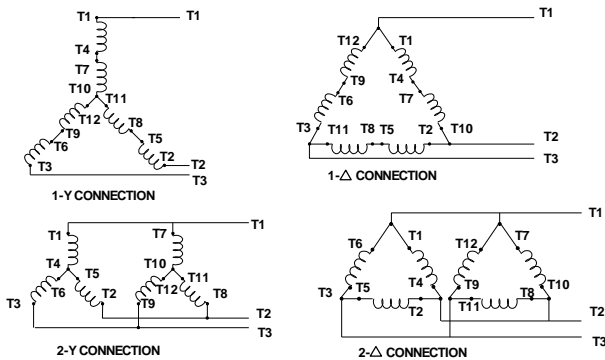

Possible motor connections.

Whatever the motor connections, you must connect the **T1** motor lead to the **T1** or **U** terminal on the motor control. You must connect the motor **T2** to the **T2** or **V** terminal on the motor control. You must connect the motor **T3** to the **T3** or **W** terminal on the motor control. Wire size must be based on the RMS current on the nameplate of the motor. The motor may draw up to 150% of this value for periods of up to one minute.

In addition to the wiring of T1, T2, and T3, you must install a ground wire, which may be one size smaller than the power leads. It must run from a ground bolt in the motor's junction box to a ground bolt on the motor control. This ground wire is in addition to required grounding of the motor to its frame.

Electrical connections to the motor must be tight and well insulated from each other and from the frame.

NOTE: Drives with IGBT output devices generate higher voltages at the motor terminals than are normally seen with bipolar transistor types. Additional care must be taken in taping and insulating of motor leads in the motor junction box.

MOTOR PROTECTION

POWERTEC Series motors come in two types:

Resolver type motors are equipped with an integral resolver mounted in the rear of the motor (non-drive end), and with two thermal switches in the windings. See page 3.

Encoder type motors are equipped with a hall-effect encoder mounted in the non-drive end of the motor and a bi-metallic thermal switch in the windings. See page 3.

Thermal switches may be used in separate control circuits up to 240 VAC. Failure to connect the motor protection properly may result in damage to the motor, or drive, or both.

BLOWER MOTOR CONNECTIONS

Cooling blowers are supplied on DPBV and TEAO motors. Blower motor connections are located in their own box on the blower motor. Blowers will vary on non-standard motors.

**SIZES 2 AND 3
3 PHASE
BLOWER MOTORS**

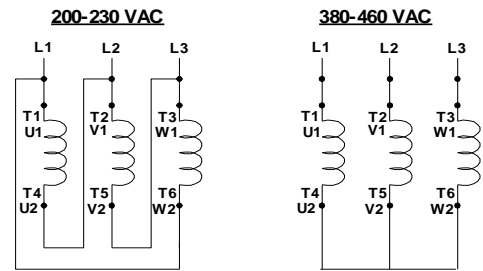

NUMBERS ARE PRINTED ON THE WIRES

WIRE COLOR:

- T1 or U1 -- BLACK
- T4 or U2 -- GREEN
- T2 or V1 -- BLUE
- T5 or V2 -- WHITE
- T3 or W1 -- BROWN
- T6 or W2 -- YELLOW

Size 2 blowers are single phase, 115VAC. These motors are impedance protected. Size 3 blowers supplied on 210T through 256T series motors are 3 phase, dual voltage design. For 200 or 230VAC input, they are connected in a delta configuration. For 380 or 460VAC operation they are connected in a star configuration. Size 8, 9, and 10 blowers use standard AC motors. They are dual voltage motors that operate on 208-230 or 460VAC. Special motors are supplied on 380VAC. Check blower motor nameplate for rating data.

If starters, fuses and overloads are not supplied with a motor control, blower motors must be supplied by proper disconnect and protective devices.

RESOLVER EQUIPPED MOTORS

The resolver supplied with **POWERTEC** motors is a frameless, single speed, transmitter type, mounted on the back of the motor. The rotor element is mounted on the shaft.

See the table at the right for resolver specifications.

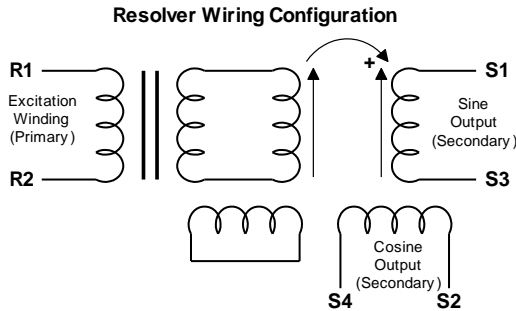

Positive resolver rotation is CW facing the resolver end of the motor.

The resolver puts out two sinusoidal waves which are in quadrature, i.e., 90° out of phase with each other. The leading wave is called the SIN output (S1 and S3) and the trailing wave is called the COS output (S2 and S4).

There is one electrical cycle of each signal for each revolution of the motor. The difference between the two waves reveals the position of the motor. By looking at the period of the waveforms, the drive can determine the speed of the motor. And by looking at which waveform is leading, the drive knows in which direction the motor is turning.

Phasing Voltage for 8 Pole Motor

for clockwise rotation at drive end

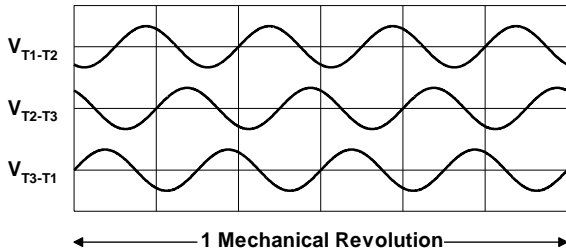

Resolver Output

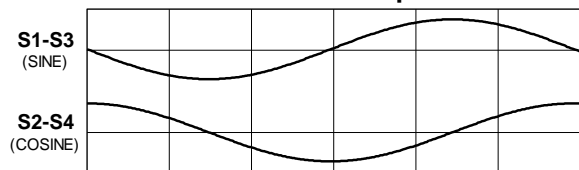

Primary Feedback Devices - - Technical Data

Frameless Resolvers
typical output @ 25°C

Parameter	Units	R1	R2	R1*
Frame Size		31	49	31
Type		Transmitter	Transmitter	Transmitter
Primary		Rotor	Rotor	Rotor
Speeds		1	1	1
Input Voltage	Vrms	8	8	4
Frequency	kHz	6.5	6.5	5
Input Current, max	mA	68	85	46
Input Power, nom	mW	404	510	100
Transformation Ratio		0.5 : 1	0.5 : 1	0.4856:1
Phase Shift	Deg	-3	-5	-5
Impedances				
ZRO	ohms	87+j82	84+j59	49+j73
ZRS	ohms	82+j79	83+j59	45+j67
ZSO	ohms	298+j519	905+j1860	131+j248
ZSS	ohms	278+j497	885+j850	122+j230
DC Resistances				
Stator	ohms	42	195	52
Rotor	ohms	57	62	33
Null Voltage	mV	45	30	15
Max Electrical Error	minutes	±20	±20	±20
Output Voltage	Vrms	4.0	4.0	1.94
Weight	lb.	1	2.43	1.3

NOTES:

- R1 resolvers are used in standard motors except as follows:
- R2 resolvers are used in all double shaft and TEFC 280 and 320 frames and all single shaft 500 frames.
- R1* resolvers are used with special drive excitation conditions. Data is for estimation purposes only. For certified data, consult the factory.

PHASING DIAGRAM OF MOTOR STATOR

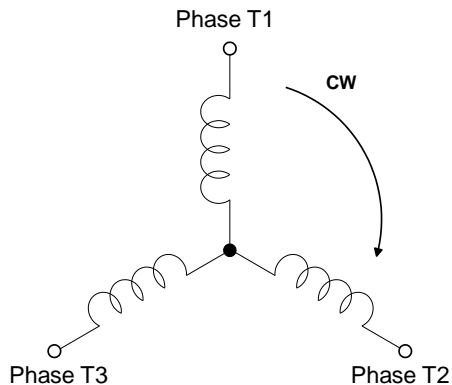

RESOLVER MOTORS - - CONNECTIONS AND TERMINAL MARKINGS

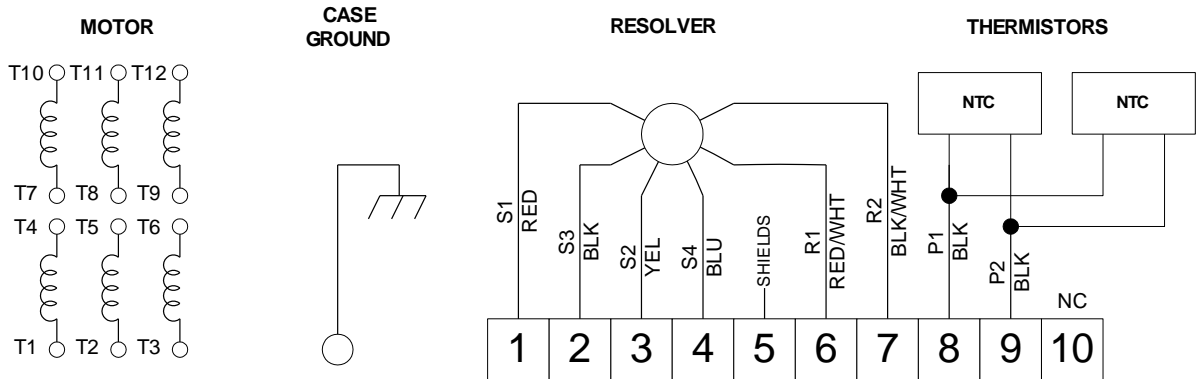

MOTOR / RESOLVER LEADS

Motors are shipped with nameplate connections (i.e., 1-Y, 1-D, 2Y, or 2-D) Check Motor nameplate for correct connections. See page 4 for connection diagrams. Consult drive manual for motor / drive interconnections.

SPACE HEATERS

When supplied, will have leads tagged H1 and H2. Check nameplate for voltage and current ratings.

OTHER ACCESSORIES

Check motor nameplate and accessories nameplates for connections and ratings.

CAUTION :

Connect cable shields to designated points only. DO NOT connect shields to ground.

THERMISTORS AND THERMAL SWITCHES

Motors with R3 Resolvers have two thermal switches connected in series embedded in the windings.

Motors equipped with R1 and R2 Resolvers have two Negative Temperature Coefficient (NTC) thermistor probes. They are 10,000 ohms each @ 25°C, connected in parallel to terminals 8 and 9 in the motor junction box. Thermistor leads are labeled P1 and P2. At Room temperature (25°C) the resistance between P1 and P2 should be 5000 ohms.

The Overtemperature threshold for totally enclosed motors is 145°C (104.2 Ohms). The threshold for drip proof and blower ventilated motors is 130°C (150.5 ohms).

Since the potential exists for a thermistor to open up, Motor Overtemperature Warnings should be set no higher than 80% of Fault Temperature on totally enclosed motors, and no higher than 80% for drip proof and blower ventilated motors.

Thermistor Resistance Table

Nominal Resistance between P1 and P2 in ohms

Resistance tolerance is +/- 5%

Winding Temp. °C	R _{P1-P2} ohms	Winding Temp. °C	R _{P1-P2} ohms
-30	88500	90	459
-20	48535	100	340
-10	27665	110	255.5
0	16325	120	194.5
10	9950	130	150.5
20	6250	140	117.5
30	4028	150	92.5
40	2663	160	74
50	1801	170	59.5
60	1244	180	48.5
70	876	190	39.7
80	629	200	32.8

ENCODER EQUIPPED MOTORS

The encoder connections must be run in a shielded cable. There are seven connections to the encoder. When the motor thermal is run in the 24VDC or 48VDC control circuit, it may also be run in the cable (except on the 320 frame motors where the thermal connections are not in the same junction box). A cable such as BELDEN® part #9539 may be used.

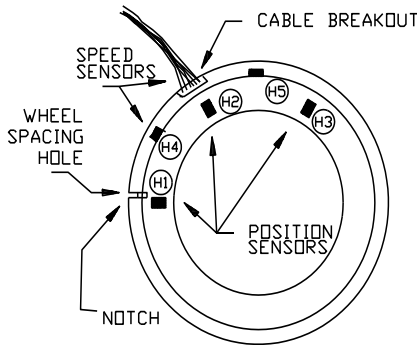

A connection diagram is supplied with each motor control. The shield should be connected at the drive end at TB1 terminal 1. The shield on the motor end should be connected to the terminal strip in the motor at terminal 10. **DO NOT GROUND THE SHIELD AT ANY POINT.** If there are junction boxes between the motor and the control, install a terminal to continue the shield through the junction box.

ENCODER ALIGNMENT PROCEDURE

If a motor has been disassembled, the encoder must be lined up again so that it is properly aligned with the magnets on the rotor and the windings of the stator. Also, if the encoder has been replaced, adjustment of the assembly is necessary.

There are two types of feedback assemblies. F1 encoders are used for motors with the junction boxes mounted on the left side of the motor (facing the drive end with the feet down) and for motors with junction boxes on the right side of the motor near the back. A top mounted box uses the F1 assembly.

F2 assemblies are for older motors with the junction box on the right side of the motor near the drive end. These encoders are for replacement use only.

PROCEDURE

1. The encoder feedback assembly mounts in the back of the motor. The hole in the end bell on the junction box side locates the cable breakout point from the feedback assembly. An end bell mark shows the notch location.
2. After the feedback assembly is mounted, but before the magnetic wheel is mounted on the shaft of the rotor, it is necessary to align the rotor with the stator. The connections on

the power leads must be made according to the nameplate (see Page 3). Start with the keyway of the motor shaft in the 12 o'clock position (up) with the motor standing on its feet

3. The alignment of the rotor may be done on small motors by attaching any battery (such as a 9 volt cell) to the power leads. The positive terminal should be connected to the T1 lead of the motor, and the negative terminal of the battery should be connected to the T2 lead of the motor. The rotor will move to the nearest pole. Do not leave the battery connected or it will quickly be drained.

On larger motors, the Genesis Series motor control may be used to align the rotor. Turn off the motor control and turn the current limit (both current limits on a regenerative drive) potentiometer(s) fully counter-clockwise. Disconnect the wires **on the motor control** at TB1 terminals 2, 3, and 4. Connect a jumper wire from TB1 terminal 16 to TB1 terminal 3 **on the motor control**. Turn on the motor control; give it a speed command of about 10%, and turn the current limit (motoring) up about 30°. The motor will align to the nearest pole. Return the motor control to its proper connections and adjustments.

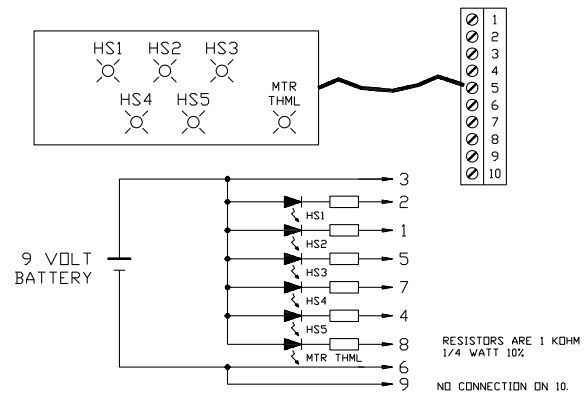

With an LED box or meter on the diode scale, put the encoder wheel on the shaft with the white mark near the cable breakout and turn the wheel on the shaft to obtain the following results (on the meter, an on sensor will have a low impedance):

	F1 Junction Box	F2 Junction Box (old motors)
HS1	ON	OFF
HS2	OFF	ON
HS3	Changing	Changing

When this condition is obtained, fasten down the encoder magnetic wheel on the shaft with the two set screws (90° apart) on the hub. The motor should now be aligned within 3° of its rotation to the stator.

MOTOR THERMAL SWITCH

SETTING NEUTRAL

The preceding procedure is used at the factory to do the initial setting of the encoder alignment. Then factory alignment marks are placed on the end bell for the position of the notch on the feedback assembly, and on the motor shaft and encoder magnetic wheel to show the alignment of the encoder parts. The previous procedure can be bypassed if the factory marks are plainly evident and the motor has not been rewound.

Installing a new encoder on the motor or reinstalling the old one may be done by the factory marks as long as the motor is properly assembled. Then it is necessary to set the actual position of the feedback assembly to set the neutral of the encoder. This is the fine tuning of the encoder alignment.

PROCEDURE

Connect a true RMS AC voltmeter to motor leads T1 and T2. Do not use a peak-reading meter.

Run the motor with no load at rated RPM in the forward direction and note the AC voltage level on the meter.

3. Run the motor in the reverse direction at rated RPM and note the voltage on the meter.

Adjust the feedback assembly (by loosening the two mounting screws) a few degrees left or right to equalize the AC voltage in both directions within one percent.

-- There is a motor temperature thermal switch in the motor, inserted in the stator windings. The motor thermal switch leads are located in the main junction box. **THIS MOTOR THERMAL SWITCH MUST BE USED TO PROPERLY PROTECT THE MOTOR!** Failure to use this switch may result in the destruction of the motor. Brushless DC motor thermal switches work better than their brush-type DC motor counterparts because the heat in a Brushless DC motor is produced in the stator, where the switch is located.

The motor thermal switch is rated as follows:

- MAX AMPS BREAK: 12 amps @ 120VAC
- 8 amps @ 240VAC
- 2 amps @ 24VDC
- CONTINUOUS AMPS: 2 amps at all voltages above.

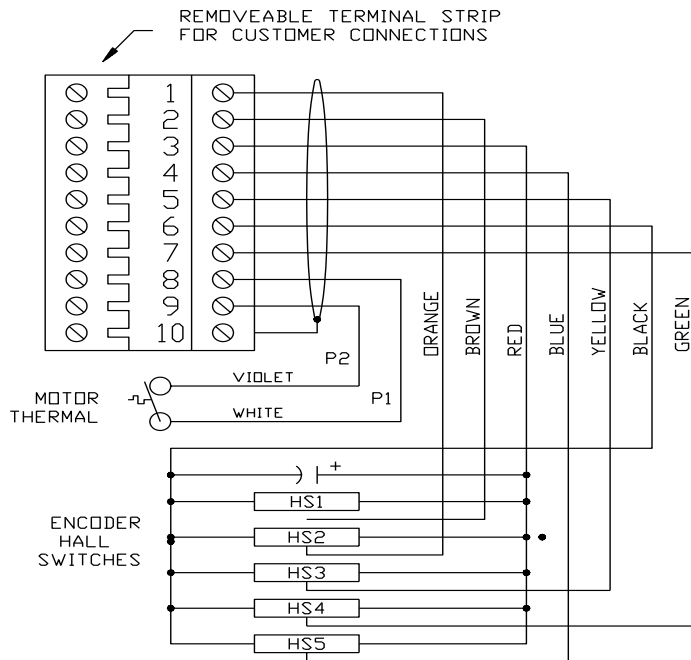

MOTOR ENCLOSURES

The enclosure type is determined by whether the motor is cooled by air moving through it, or by convection to the ambient air around it, or by air moving over it. CONSTANT TORQUE SPEED RANGE (CTSR) is a thermal consideration. The constant torque speed range is the range of speeds (based on base speed) over which the motor will run at full load without overheating or de-rating. De-rating the motor beyond its speed range does not mean it will not put out full torque. It means the motor cannot thermally support full torque output *continuously*.

DPFG -- DRIP PROOF, FULLY GUARDED

The drip proof fully guarded motor moves air through the motor by means of an internal, shaft driven fan. Louvered covers in the front and rear of the motor prevent foreign matter from entering the motor when dropped from above or at an angle of up to 18° from the vertical. The Constant Torque Speed Range of the DPGF motor may be 2:1 or 100: 1, depending upon the frame size.

DPBV -- DRIP PROOF, BLOWER VENTILATED

The drip proof, blower ventilated motor uses forced air through the motor to cool it. The blower is generally mounted at the rear of the motor (at the non-drive end) and the forced air is exhausted out the front of the motor. The blower is separately powered. The CTSR is normally 100:1 or better.

TENV -- TOTALLY ENCLOSED, NON-VENTILATED

The totally enclosed non-ventilated motor is dust-tight with no openings to the ambient air. The motor is cooled by natural convection and radiation. The CTSR of the TENV motor is 100:1 or greater, but the horsepower range is limited to smaller sizes.

TEFC -- TOTALLY ENCLOSED, FAN COOLED

The totally enclosed fan cooled motor is dust-tight with no openings to ambient air. A shaft-mounted fan on the non-drive end of the motor cools the motor. This allows higher horsepowers than TENV. The CTSR of TEFC motor is 2:1.

**TEAO -- TOTALLY ENCLOSED, AIR OVER, OR
TEBC -- TOTALLY ENCLOSED, BLOWER COOLED**

If a totally enclosed applications requires a wider speed range and larger horsepowers, the totally enclosed, air over (blower cooled) motor has a constant speed fan, which blows air over the motor’s external surface to cool it. Since the air volume is constant with speed, the Constant Torque Speed Range of the TEAO motor is 100:1.

TEWC -- TOTALLY ENCLOSED, WATER COOLED

For still larger sizes of totally enclosed motors, the totally enclosed, water cooled motor removes heat by means of a water jacket. Cooling water, or other liquid, may be used in a closed or open system. The CTSR is 100:1 or greater.

This list is not a complete listing of all types, nor is the description complete. For further information on motor enclosures, consult NEMA Publication No. MG1.

MOTOR COOLING REQUIREMENTS

FORCED AIR COOLING

DPBV and TEAO motors require forced-air cooling, which is accomplished by a centrifugal blower and AC motor. **Separately Ventilated** motors (**DPSV**) require the user to supply a forced air stream to cool the motor. Whether supplied by **POWERTEC** or others, the cooling blowers must have minimum specifications as follows:

FRAME	AIRFLOW CFM	STATIC PRESSURE inches of water	BLOWER SIZE
182T, 184T	100	0.9	2
213T, 215T, 219T	200	1.9	3
254T, 256T	223	1.6	3
259T, 2512T	270	2.6	8
287T, 288T, 2810T, 2812T	425	4.6	9
328T, 3211T, 3213T	660	4.0	10
504ATZ, 506ATZ, 508ATZ	1500	1.1	12

Check the motor blower nameplate for the voltage and current requirements of your blower.

WATER COOLING

Cooling water for TEWC motors must enter the motor at no more than 40 °C. To maintain a maximum temperature at the water outlet of 55 °C, the following minimum flow rates must be maintained for each frame size listed:

FRAME	FLOW RATE (GPM)
254T	0.8
256T	1.3
259TZ	1.7
288TZ	1.8
2810TZ	2.2
2812TZ	2.7
328TZ	3.4
3211TZ	4.0
3213TZ	4.0

Other cooling liquids and/or additives may be used. Consult the factory for the required flow rates.

MOTOR SERVICE PROCEDURE

Any competent motor shop that can overhaul AC induction motors may service Brushless DC motors. There are differences that must be observed in the permanent magnet rotor, the feedback, and the bearings.

PERMANENT MAGNET ROTOR - Permanent magnets used in the Brushless DC motor are constructed of a highly stable material and will not demagnetize under normal conditions. The motors can be disassembled and reassembled without affecting the strength of the magnets.

HANDLE THE ROTOR WITH GREAT CARE SINCE THE MAGNETS ARE BRITTLE AND CAN BE DAMAGED IF DROPPED! DO NOT SET ON A STEEL SURFACE!

RESOLVER - The resolver consists of two parts: a rotor mounted on the shaft and the stator attached to the motor's end bell at the non-drive end. These components must line up properly if the motor is to operate correctly. See page 8 for the encoder alignment procedure after re-assembling an encoder equipped motor.

BEARINGS -- Bearings are press-fit on the rotor shaft. The rear (non-drive end) bearing is fixed in place by a bearing retainer plate, and both bearings are slip fit into their housings. When replacing bearings, they must be positioned up against the bearing shoulder on the shaft.

DIS-ASSEMBLY OF THE MOTOR

Refer to exploded view drawing and parts list on page 4. This is a general drawing, and not all details are shown.

1. Before disassembling the motor, remove the rear cover (#19) from the bracket (#14) to expose the resolver.
2. Make sure that there are marks on the end bells (#14 and #22), frame (#25), resolver assembly (#15), resolver rotor (#17), and motor shaft (#2) to locate parts when the motor is reassembled. Be sure those marks will not be obscured in the process.
3. Remove the resolver rotor (#17) from the shaft. It is secured by two set screws (#16) 90° apart on the hub.
4. Remove the two bearing retainer plate screws (#13) in the non-drive end. In some cases this may require loosening the two set screws (#18) holding the resolver assembly (#15) and moving the resolver stator out of the way. This releases rear bearing (#4) and allows removal of the shaft or end bell.
5. Remove four bolts (#11) that hold the drive end bracket (#22) on. Some motors have hex nuts on overbolts that run the length of the motor. Note the location of the lifting lugs (#21).
6. Carefully slide the drive end bracket (#22) off of the shaft (#2). Don't allow the end bell to scrape the shaft as it is removed. Note carefully the location of parts that come loose as the end bell is removed, such as the wave washer (#23) in the front housing. The rotor stays in the frame assembly.
7. The rotor (#2) may now be removed by sliding it

slowly out. The banding will protect the magnets against damage while sliding out straight. Avoid jerky side to side movements. While the rotor is out of the motor, protect the banding and magnets from sharp blows and pointed objects.

8. If only the rotor assembly is to be serviced, it is not necessary to remove the resolver end bracket (#14). If the motor stator is to be rewound, then the resolver end bracket should be removed. Remove the two set screws (#18) holding the resolver (#15) in place. Before removing the resolver, disconnect the wires from the block (#31) in the motor junction box and tie a string onto the wires. This will help cable reinstallation. Remove the assembly.

DO NOT PULL ON THE WIRES OF THE CABLE OR ON THE ASSEMBLY. Pull the outside cable jacket only.

RE-ASSEMBLY OF THE MOTOR

1. Make sure the inside surface of the stator is smooth with no foreign material (such as metal shavings) in the area. Also check rotor assembly for foreign matter (like metals).
2. Carefully slide the rotor (#2) into the stator assembly (#25) slowly, **BEING VERY CAREFUL TO AVOID INJURY TO THE HANDS OR ARMS**. Make sure you insert the rotor from the drive end of the frame.
3. Once the rotor is inside the stator assembly, the resolver end bracket (#14) may be installed. Make sure the marks made before disassembly line up properly. Use long screws to position the bearing retainer plate before pushing end bell in. Replace bearing retainer plate screws (#13).
4. Position the air baffle (#24 - not TENV motors), and place the wave washer (#23) in position in the front housing. Replace drive end bracket (#22) according to the marks made before disassembly, being careful not to scratch the shaft.
5. Reinsert four bolts (#11) into holes in the end bells of the motor (don't forget the lifting lugs - #21), making sure the end bells are seated properly in the ends of the frame.
6. Install the resolver (#15) according to the orientation marks and connect cable leads to the block in the junction box (#31) according to the drawing on page 7.
7. Reinstall rotor (#17) on the shaft aligning the marks.
8. Turn the motor by hand to check for rubbing, scraping, and make sure the shaft turns freely. Check for lengthwise and sideways movement of the shaft.
9. Torque down all bolts and screws, and proceed to motor resolver alignment or motor encoder alignment.

TROUBLESHOOTING

When a motor does not operate as expected, there may be a valid reason other than that the motor is bad. **Troubleshooting involves looking at the entire system of motor, control and environment.** Problems that occur when a motor is first put into service are most likely caused by misapplication, improper connection or lack of understanding. Problems that occur after a motor has been in service for some time period may be due to motor, control or environment.

These troubleshooting tips cover possible problems as well as problems which were seen in the past.

PROBLEM SHAFT ROCKS BACK AND FORTH

1. Motor leads T1, T2, and T3 are not connected to the corresponding terminals on the motor control. T1 MUST be connected to T1, T2 MUST be connected to T2 and T3 MUST be connected to T3.
2. Encoder cable is connected to control improperly. Check the connections to the control per the card supplied with the control. The main connections involved are the connections involving HS1, HS2, and HS3.

PROBLEM ERRATIC SPEED

1. Motor is going at or above base speed while cold. Allow motor to warm up before adjusting maximum speed.
2. Feedback cable from motor to control is improperly shielded, run with power cables, or defective. Check the cable connections per the card supplied with the control.
3. Feedback signals are improper or missing. Check resolver signals against wave forms on page 6. Check encoder waveforms against drawing below. The drawing below is for a four pole motor. An eight pole motor will have the same waveforms, but the interval marked as being 1/2 revolution of the motor in the drawing below will be 1/4 revolution in an eight pole motor.
4. Bearings are worn. This will likely show up as increased current and an overheating motor, but severe bearing problems may affect speed control of the drive.
5. Severe load variations, such as a high inertia load changing speeds quickly may result in speed being erratic. Consult POWERTEC.
6. Drive is unstable. Adjust gain and/or stability

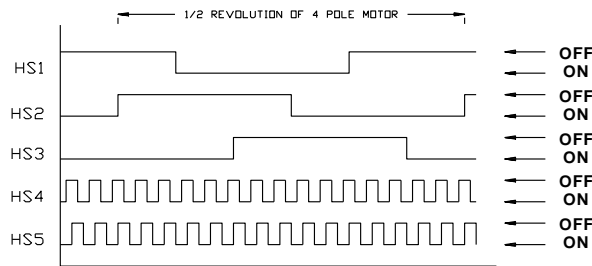

WAVEFORMS OF ENCODER SIGNALS FROM BRUSHLESS DC MOTOR.

Encoder waveforms

PROBLEM EXCESS END PLAY OF THE SHAFT

Check for excessive thrust loading on the shaft.

1. Check the tightness of the bearing retainer plate by checking the bearing retainer plate screws on the non-drive end. (On some motors, these screws may be partially or completely hidden by the feedback assembly.)
2. The bearings may be excessively worn.
3. The shaft bearing journals may be shot.

PROBLEM EXCESS RADIAL SHAFT PLAY

* Make sure radial loading on shaft is not excessive.

1. The shaft may be loose in the bearing I.D.
2. The bearings may be excessively worn.
3. The bearing housing may be worn.

PROBLEM EXCESS VIBRATION

1. The load may be out of balance. Check the load balance.
2. The motor mounting bolts may be loose. Check for tightness.
3. The rotor may be unbalanced. Run the motor unloaded.
4. There may be excessive radial play. See above.
5. The bearings may be worn. Listen for bearing noise.
6. Noise on drive speed reference.

PROBLEM MOTOR RUNS HOT LOADED

DO NOT JUDGE MOTOR TEMPERATURE BY TOUCH. USE A TEMPERATURE MEASURING DEVICE.

1. Check ambient temperature. It must be less than rated (40°C).
2. Check the load on the motor. Do not exceed rated current.
3. Check the duty cycle of the motor. It may not exceed 100% RMS.
4. The brake, if there is one, may not be releasing.
5. The bearings may be worn. Run motor unloaded.
6. The rotor may be rubbing the stator. Listen for noise.

PROBLEM MOTOR RUNS HOT UNLOADED

1. Check all items under Motor runs hot loaded.
2. The motor control may be misadjusted. Check motor control.
3. The encoder or resolver may be improperly set up. See Page 6.
4. The motor may be demagnetized. Check terminal voltages.

PROBLEM MOTOR RUNS TOO FAST

1. Check the maximum speed setting on the motor control.
2. HS4 and HS5 on the encoder signals may be swapped.
3. Resolver or encoder misaligned.
4. Motor may be demagnetized. Check terminal voltages.

PROBLEM LOW OUTPUT TORQUE

1. Improper alignment of feedback device
2. Open power connection.
3. Open or shorted stator windings.
4. Motor may be partially demagnetized.

ROUTINE MAINTENANCE

Observe the motor during operation, checking for excess vibration, unusual noises and excess heat.

1. VIBRATION

1. Check for signs of excess vibration. It may be the result of poor alignment, worn or loose couplings or sheaves, or damaged bearings. It may be a poorly designed base. Excess vibration causes damage to the bearings, shaft, mounting feet and accessories.
2. Noise on the speed reference input to high performance drives has been known to cause vibration in motors.
3. When checking balance on an unloaded motor, install a half key in the shaft keyway.

2. NOISE

1. Listen for noise in the area of the bearing housings. Rubbing noises may be a sign of internal damage.
2. A steady high pitched hum is normal in a BLDC motor, and there may be short interruptions of this hum under no load conditions. If you hear growling or an erratic hum above 20 RPM, check the drive.

3. TEMPERATURE

1. Drip Proof Fully Guarded (DPFG), Drip Proof Blower Ventilated (DPBV), and Totally Enclosed Air Over (TEAO) motors may run at surface temperatures in excess of 85°C.
2. Totally Enclosed motors (TENV) may have surface readings as high as 100 °C. Before checking the temperature of a motor, check the load on the motor.

Use a thermal probe for an objective reading

DO NOT CHECK MOTOR TEMPERATURE WITH YOUR BARE HAND!!! HIGH TEMPERATURES MAY CAUSE BURNS!

4. FEEDBACK DEVICE

1. The feedback device is located inside the motor. It requires no maintenance unless you disassemble the motor.
2. The alignment of the motor feedback device is important. If it is removed, it must be re-installed correctly.

5. BRAKES

1. Brakes supplied on "F" series Brushless DC motors are fail-safe, disk type brakes. You release the brake by energizing the brake coil. There may be a manual release.

2. The brakes do not normally require adjustments, but the pads may have to be changed periodically if the brake is used for stopping duty.

6. SECONDARY FEEDBACK DEVICE

Check externally mounted encoders (coupling and mounting bolts) periodically for tightness.

7. COOLING BLOWERS AND FILTERS

Cooling blowers are AC motors that require little maintenance. They have a lubrication life of 15,000 to 40,000 hours.

ATTEMPTING TO SERVICE THE FILTER WHILE THE BLOWER MOTOR IS RUNNING MAY CAUSE INJURY.

1. Be sure the blower is running in the correct direction, which is in the direction of the arrow on the blower scroll.
2. Clean out multi-cripp filters with a solvent. Let dry thoroughly. Spray with an air filter adhesive and drain excess.
3. Before re-mounting the filter, be sure that there is no build-up of material inside or on the blades of the impeller.

8. BEARINGS AND RE-LUBRICATION

1. 42, 140, and 180 frame motors have permanently lubricated bearings. Replace damaged or worn bearings.
2. Frames 210 and larger are lubricated at the factory with Chevron SRI #2 grease. Suitable substitutes are Amoco's RYKON Premium #2, Texaco's Polystar B, or EXXON's Polyrex. Do not use the "EP" versions of these greases. High-speed motors use Kluber HB72-52.
3. Use the table below for bearings of standard motors with standard or maximum capacity bearings. These motors have a "0" or "1" as the 10th digit in the Model Number. Re-lubricate vertically mounted motors at 1/2 the table interval.
4. Roller bearings are indicated by a "2" in the tenth position of the Model Number. Re-lubricate these at 1/2 of the table interval. For vertically mounted motors, use ¼ of the interval. For high speed motors, consult the graph on page 16. High-speed motors have a "9" in the tenth position.

Lubrication Interval in Operating Hours - STANDARD BALL BEARINGS only				
HORIZONTALLY MOUNTED, AVERAGE MOTOR SPEED (RPM)				
FRAME	1150	1750	2500	3600
42	28,000	18,000	13,000	8,500
140	23,000	14,000	10,000	6,700
180	19,000	12,000	8,000	5,400
210	16,000	10,000	6,300	3,800
250	13,500	8,000	5,000	2,900
280	11,500	6,600	3,900	2,200
320	9,600	5,600	3,000	1,400
500	6,400	3,200	500	N/A

If a motor has no grease fittings, the bearings must be replaced.

loaded systems and systems that are dynamic may require careful study in choosing a suitable mounting system, grade of bolt to be used, and hence the required bolt torques.

MOUNTING BOLT TORQUES

Motors must be mounted on a solid, rigid base or foundation. Poor base design can result in resonance in the motor/base system that can result in bearing, motor feet, frame to foot fasteners, or other, and motor damage.

All hold-down bolts must be of the correct grade for the type of mounting, and for the method of coupling the motor to the load. Some considerations are:

1. Direct coupled or belt drives
2. Motor feet orientation (horizontal, wall, or ceiling mounting).

Bolts must be evenly torqued to their recommended value. Recommended bolt torques for SAE grade foot bolts are given below in foot-pounds. (All components are dry, i.e., not lubricated):

Foot Bolt Frame Hole Size Diam	Steel Size & Third	Steel Grade 1	Steel Grade 5	Socket Head
42 .34	5/16-18	10	15	25
140 .34	5/16-18	10	15	25
180 .41	3/8-16	16	26	42
210 .41	3/8-16	16	26	42
250 .53	1/2-13	39	63	100
280 .53	1/2-13	39	63	100
320 .69	5/8-11	77	125	200
500 1.19	1-8	320	500	820

Motors with aluminum feet require a suitable heavy flat steel washer between the foot and the mounting fasteners to spread the bolt-clamping load out over a suitable area.

The above values are suitable for most applications. Heavily

RADIAL LOADING OF THE MOTOR

When a motor is driving a belt-driven load, care must be taken to prevent the side pulling forces to damage the bearings and/or the shaft of the motor.

MAXIMUM SHAFT RADIAL LOADING				
Standard Ball Bearings and standard shaft extension				
Radial Load Centered at tip of Shaft				
Expected L10 life at 1750 RPM average speed of 20,000 hours				
Frame/ Series	Shaft Diam	Bearing #	Max Radial Load (lbs.)	Min Sheave Dia (in.)
42	0.625	203	90	0.9
140	.875	205	180	2.4
182/184	1.125	207	280	4.6
213/215	1.375	209	440	4.4
219	1.625	209	650	4.0
254/256	1.625	211	600	6.5
259/2512	2.125	M211	1100	6.0
287	2.125	313	1100	6.0
288/2810/2812	2.375	313	1350	9.6
328/3211/3213	2.875	315	1800	12.0
504	3.25	6222 / 6222W	1500 / 2200	21.6 / 14.7
506	3.625	6222 / 6222W	1400 / 2100	30.9 / 20.6
508	4.125	6222 / 6222W	1300 / 2000	41.5 / 27.0
If radial loads exceed the "Max Radial Load", or the sheave diameter is too small roller bearing are required.				
500 frames with ball bearings are recommended for direct coupled service only Belt drives with 500 frame motors require roller bearings in the drive end.				

MOTOR NAMEPLATE DATA

FRAME

An alphanumeric designation of the size of a motor. These designations are standardized in the USA by the National Electrical Manufacturers Association (**NEMA**). For standard NEMA frames 140 and larger, the first two numbers are four times the height of the center of the motor shaft above the feet. The third and fourth (if used) numbers indicate the distance between the mounting holes on the feet lengthwise, but a table is necessary to find the actual distance.

MODEL

The **MODEL** number of the "F" series motors is a description of how the motor is put together. The model number describes the windings and connections as well as frame size, configuration, and options.

HP

The rated output horsepower of the motor is listed in the **HP** block. This value of horsepower is only valid at base speed, or above base speed, if the drive is equipped to operate in extended speed range.

RPM

The base speed of the motor, the speed at which rated horsepower is developed. From zero to this speed is the **CONSTANT TORQUE** speed range. If there are two numbers in this block with a slash between them, the first number is the base speed and the second number is the top speed. Between these two speeds is the **CONSTANT HORSEPOWER** range.

BUS VDC

For a Brushless DC motor, this is the voltage level of the DC supply from which the drive operates the motor. In most cases, this value is the nominal capacitor bank voltage level, which is about 1.4 times the RMS value of the AC input to the drive.

DUTY

This is a rating which may limit how the motor is used. If the designation **CONT** is in this block, the motor may be used for continuous duty up to its full ratings. A 30 MIN rating in the **DUTY** block indicates that the motor may be run to its full rating for 30 minutes, after which it must cool to ambient temperature.

RMS AMPS

This is the per phase motor current (in RMS AC amperes) required to develop full load torque on a motor that has reached its steady state operating temperature.

S.F.

The **SERVICE FACTOR** is a multiplier to the HP, indicating how much power may be used under rated conditions.

INSUL. CL.

INSULATION CLASS "F" is rated for 105°C rise above an ambient temperature of 40°C. Class "H" is rated for 125°C rise. The motor over-temperature protector is set to correspond.

AMB °C

The **AMBIENT TEMPERATURE** in which the motor operates should not exceed this number.

ENCL

This is the type of enclosure of the motor. In Europe, it is called the **PROTECTION CLASS**. There are two basic types: **OPEN** and **CLOSED**. See "MOTOR ENCLOSURES" on page 6 for a description of the standard **NEMA** motor enclosures.

C.T. SPD. RANGE

This is the ratio of speeds, based on **BASE SPEED**, over which the motor may be operated at full torque continuously. This is a **THERMAL** limitation. This does not guarantee smooth operation, only that the motor is able to cool itself at full torque over this range.

CONNECTION

This is either 1-D or 2-D, 1-Y or 2-Y. (D = delta; Y = wye) This refers to the connection of the windings. See "Motor Winding Connections" for details on the connections.

PEAK RMS AMPS

Do not exceed this value at any time. This is the maximum safe current which will not affect the permanent magnets.

INTEGRAL ENCODER

This number is the pulses per revolution (**PPR**) which will be seen in one channel of the speed feedback (HS4 or HS5) from the internal encoder. The two channels are 90° out of phase with each other, i.e., they are in **QUADRATURE**. For small motors the number should be 30. Large motors should be 60.

KE V/KRPM

This is the RMS voltage which should be observed between any two power leads of the motor at 1000 RPM. This measurement is taken with the windings at room temperature (25 °C). Actual voltage at operating temperature may be as low as 90% of the 25 °C value.

SERIAL NO.

Use when calling to ask questions or to order spare parts. This number is also stamped into the frame near the junction box.

JOB NO.

This is a factory in-house number for the factory build job that included this motor.

BEARING RELUBRICATION INTERVAL CHART

USE THIS CHART TO ESTIMATE THE RELUBRICATION INTERVAL AT SPEEDS OTHER THAN BASE SPEED AND FOR HIGH SPEED MOTORS.

This chart is based on the use of Mobil SHC 1500 or Klubersynth HB 72-52 (high speed) grease.

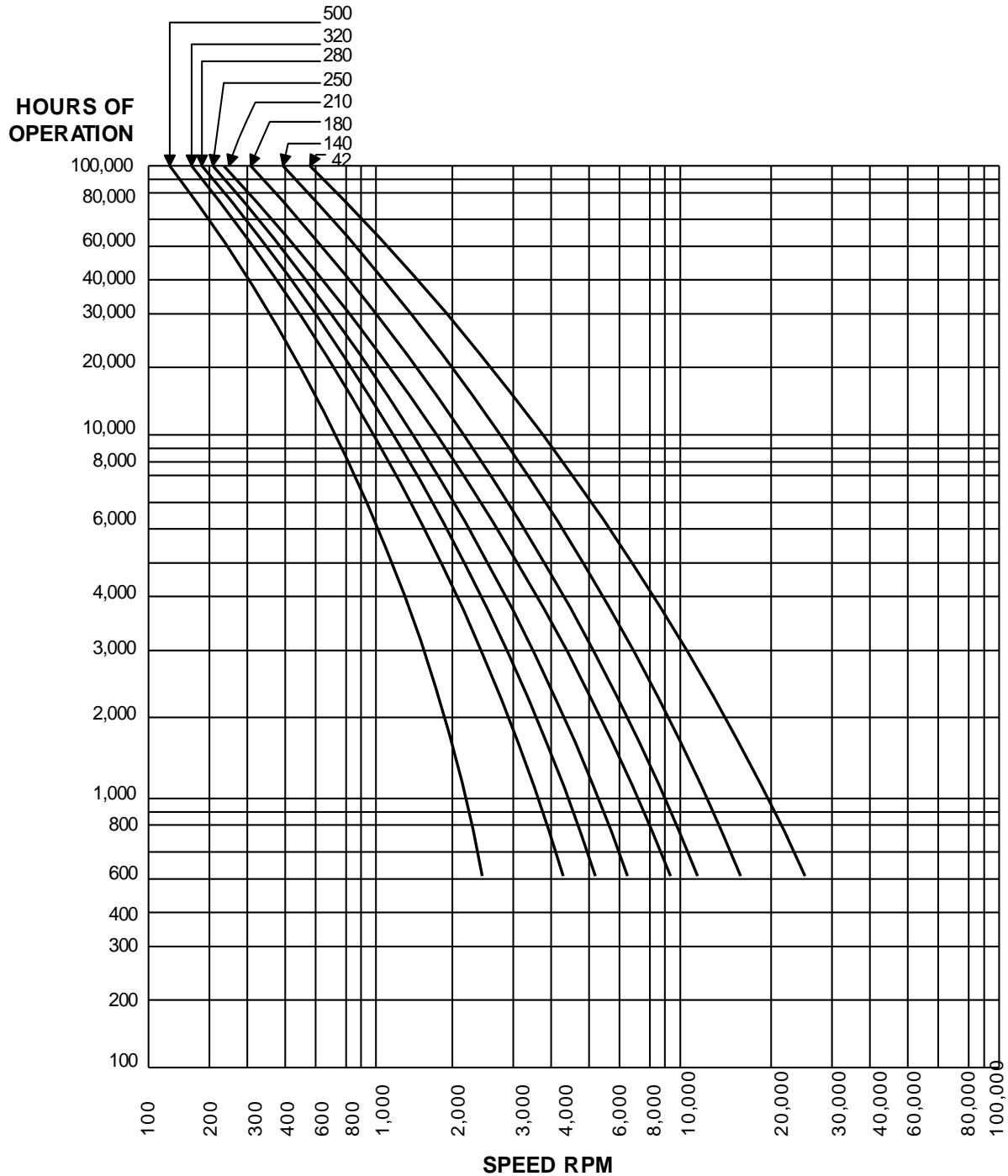

POWERTEC
INDUSTRIAL MOTORS, INC.

2012

P/N 2093-000000-002

POWERTEC Industrial Motors

13509 South Point Blvd. • Suite 190 • Charlotte, NC USA 28273 • PHONE: 704-227-1580
Internet: powertecmotors.com • E-mail: sales@powertecmotors.com